

Flow Meter Nominal Size	L	H	WEIGHT
1/2 inch (15mm)	4.56 in (116 mm)	14.8 in (376 mm)	9.8 Lb (4.4 Kg)
3/4 inch (20mm)	4.8 in (122 mm)	15 in (381 mm)	10 Lb (4.5 Kg)
1 inch (25mm)	2.8 in (71 mm)	14.8 in (376 mm)	10.1 Lb (4.6 Kg)
1-1/2 inch (40mm)	2.8 in (71 mm)	15.1 in (384 mm)	11.9 Lb (5.4 Kg)
2 inch (50mm)	3.0 in (76 mm)	15.3 in (389 mm)	14.1 Lb (6.4 Kg)
3 inch (80mm)	4 in (102 mm)	15.8 in (401 mm)	22.7 Lb (10.3 Kg)
4 inch (100mm)	4.7 in (119 mm)	16.2 in (411 mm)	33 Lb (15.0 Kg)

Add 11 Lb (5 KG) for remote electronics

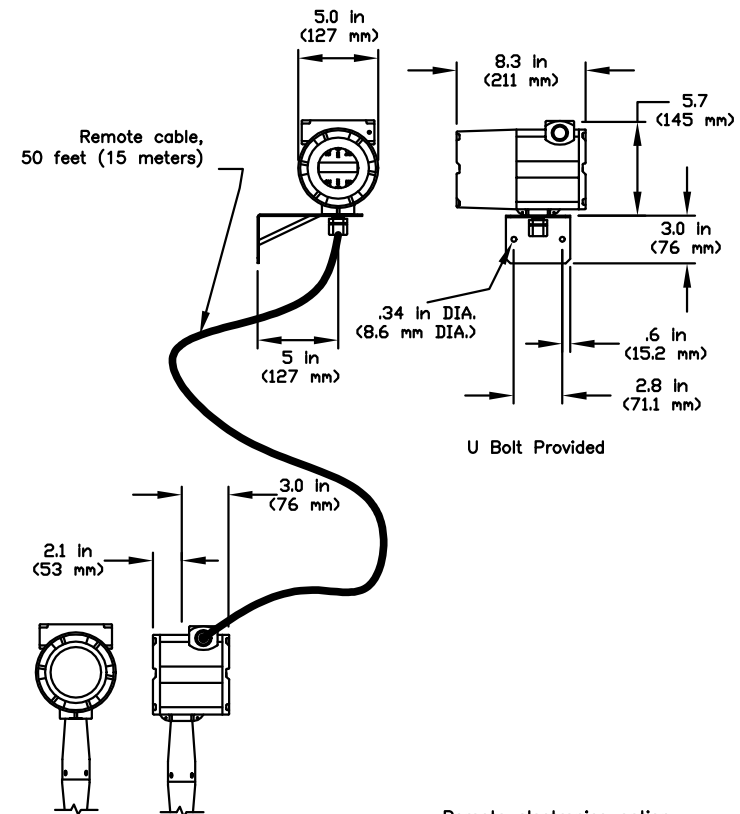

Remote electronics option available on all models

VORTEK INSTRUMENTS, LLC

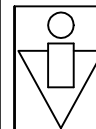

8475 WEST I-25 FRONTAGE RD
SUITE 300
LONGMONT, CO 80504
(303) 682-9999

M22 INLINE VORTEX,
WAFER MODELS

DATE: 6-15-10

DWG NO: V1370

SCALE: NTS

BY: CTO

REV: A

PAGE: 1 of 1