

# **VorTek Pro-T™ Model Turbo-Pro™ Insertion Turbine Volumetric and Mass Flow Meters**

## **Instruction Manual**

Document Number M-000-00020  
Rev 03/2021



8475 W I-25 Frontage Rd  
Suite 300  
Longmont, CO 80504  
(303) 682-9999 (888) 386-7835 Fax (303) 682-4368  
<http://www.vortekinst.com>

## Customer Notice for Oxygen Service

This flow meter is not intended for oxygen service. VorTek Instruments, LLC is not liable for any damage or personal injury, whatsoever, resulting from the use of VorTek Instruments insertion turbine flow meters for oxygen gas. If oxygen service is required please consult factory.

## Specific Conditions of Use (ATEX/IECEX)

Contact Manufacturer regarding Flame path information.

Clean with a damp cloth to avoid any build-up of electrostatic charge.

The Model Pro-T Multivariable Mass Turbine Flowmeters standard temperature option (ST) process temperature range is -40°C to +232°C. The high temperature option (HT) process temperatures range is -40°C to +454°C.

The Model Pro-T Multivariable Mass Turbine Flowmeters		
Tmax (Process)	Temperature Class Value (Gas)	
	ST Version	HT Version
80°C	T6	85°C
95°C	T5	100°C
130°C	T4	135°C
195°C	T3	200°C
232°C	T2	300°C
445°C	N / A	450°C
454°C	N / A	459°C



### Notice to Users

Warning based on Electric Appliances Safety Control Act of Korea. This product should be handled as electromagnetic radiation emitting equipment, and is intended for use by industrial dealers and end-users. It is not for residential use.

NIST Standard Reference Database 23, NIST Reference Fluid Thermodynamic and Transport Properties: REFPROP Version 9.x. Standard Reference Databases are copyrighted by the U.S. Secretary of Commerce on behalf of the United States of America. All rights reserved. No part of the database may be reproduced, stored in a retrieval system or transmitted, in any form or by any means, electronic, mechanical, photocopying, recording or otherwise without prior permission.

© COPYRIGHT VORTEK INSTRUMENTS 2021

No part of this publication may be copied or distributed, transmitted, transcribed, stored in a retrieval system, or translated into any human or computer language, in any form or by any means, electronic, mechanical, manual, or otherwise, or disclosed to third parties without the express written permission of VorTek Instruments. The information contained in this manual is subject to change without notice.

TRADEMARKS

Pro-T™ is a trademark of VorTek Instruments, LLC. Other product and company names listed in this manual are trademarks or trade names of their respective manufacturers.

## Table of Contents

### Chapter 1 Introduction

Pro-T™ Multi-Variable Turbine Mass Flow Meters .....	1-1
Using this Manual .....	1-2
Note and Safety Information .....	1-3
Receipt of System Components .....	1-3
Technical Assistance .....	1-3
How the Pro-T™ Turbine Mass Flow Meter Operates.....	1-4
Velocity Measurement .....	1-4
Flow Velocity Range.....	1-4
Temperature Measurement.....	1-5
Pressure Measurement.....	1-5
Flow Meter Configuration .....	1-5
Multivariable Options .....	1-5
Line Size / Process Connections .....	1-6
Flow Meter Electronics .....	1-6

### Chapter 2 Installation

Installation Overview.....	2-1
Flow Meter Installation Requirements .....	2-1
Unobstructed Flow Requirements .....	2-2
Insertion Flow Meter Installation .....	2-3
Cold Tap Guidelines.....	2-4
Hot Tap Guidelines .....	2-5
Flow Meter Insertion .....	2-7
Installing Meters with a Compression Connection .....	2-8
Installing Meters with a Packing Gland Connection.....	2-10
Installing Meters (Packing Gland), No Insertion Tool.....	2-13
Display/Keypad Adjustment .....	2-15
Loop Power Flow Meter Wiring Connections.....	2-16
Input Power Connections .....	2-16
4-20 mA Output Connections.....	2-17
Pulse Output Connections .....	2-18
Frequency Output Connections .....	2-19
Optional Backlight Connections .....	2-19
Remote Electronics Wiring .....	2-20
High Power Flow Meter Wiring Connections .....	2-22
Input Power Connections .....	2-22
4-20 mA Output Connections.....	2-24
Frequency Output Connections .....	2-25
Pulse Output Connections .....	2-26
Alarm Output Connections.....	2-28
Remote Electronics Wiring .....	2-29
Optional Input Electronics Wiring .....	2-30
Optional Energy EMS RTD Input Wiring .....	2-30
Optional External 4-20 mA Input Wiring .....	2-31
Optional Contact Closure Input Wiring .....	2-32

## Chapter 3 Operating Instructions

Flow Meter Display/Keypad.....	3-1
Start Up.....	3-2
Using the Setup Menus.....	3-4
Programming the Flow Meter.....	3-5
Output Menu.....	3-6
Display Menu.....	3-8
Alarms Menu.....	3-9
Totalizer #1 Menu.....	3-10
Totalizer #2 Menu.....	3-11
Energy Menu.....	3-12
Fluid Menu.....	3-13
Units Menu.....	3-14
Time and Date Menu.....	3-15
Diagnostics Menu.....	3-16
Calibration Menu.....	3-17
Password Menu.....	3-18

## Chapter 4 Serial Communications

HART Communications.....	4-1
Wiring.....	4-1
HART Commands with the DD Menu.....	4-3
HART Commands with Generic DD Menu.....	4-8
MODBUS Communications.....	4-9
Wiring.....	4-9
Menu Items.....	4-10
Register Definitions.....	4-12
BACNET MSTP Communications.....	4-19
BACNET MSTP Description.....	4-19
Baud Rates on the MS/TP Bus.....	4-19
Supported BACnet Objects.....	4-20
ANNEX - BACnet Protocol Implementation Conformance Statement.....	4-26
Acronyms and Definitions.....	4-32

## Chapter 5 Troubleshooting and Repair

Hidden Diagnostics Menus.....	5-1
Level One Hidden Diagnostics Values.....	5-3
Level Two Hidden Diagnostics Values.....	5-4
Analog Output Calibration.....	5-7
Display Contrast Adjustment.....	5-7
Troubleshooting the Flow Meter.....	5-8
First Check Items.....	5-8
Record Values.....	5-8
Determine the Fault.....	5-9
Symptom: Output at no Flow.....	5-9
Symptom: Erratic Output.....	5-9
Symptom: No Output.....	5-11
Symptom: Meter Displays Temperature Fault.....	5-12

Symptom: Meter Displays Pressure Fault .....	5-13
Electronics Assembly Replacement.....	5-14
Returning Equipment to the Factory.....	5-15

## Appendix A Product Specifications

## Appendix B Approvals

## Appendix C Flow Meter Calculations

## Appendix D Glossary

### Figures

1-1. Insertion Turbine Multivariable Mass Flow Meters .....	1-1
2-1. Recommended Pipe Length Required for Installation.....	2-2
2-2. Hot Tap Sequence.....	2-6
2-3. Insertion Calculation (Compression Type).....	2-8
2-4. Flow Meter with Compression Type Fitting.....	2-9
2-5. Insertion Calculation (Meters with Insertion Tool) .....	2-10
2-6. Flow Meter with Permanent Insertion Tool.....	2-11
2-7. Flow Meter with Removable Insertion Tool.....	2-12
2-8. Insertion Calculation (Meters without Insertion Tool) .....	2-13
2-9. Display/Keypad Viewing Adjustment .....	2-15
2-10. Loop Power Wiring Terminals .....	2-16
2-11. DC Power Connections.....	2-16
2-12. Load Resistance Versus Input Voltage.....	2-17
2-13. Isolated Pulse Output Using External Power Supply .....	2-18
2-14. Non-Isolated Pulse Output Using External Power Supply ...	2-18
2-15. Isolated Frequency Output Using External Power Supply ...	2-19
2-16. Non-Isolated Freq. Output Using External Power Supply....	2-19
2-17. Backlight Using External Power Supply .....	2-19
2-18. Loop Power Volumetric Flowmeter Junction Box .....	2-20
2-19. Loop Power Volumetric Flowmeter Junction Box Prior .....	2-21
2-20. Loop Power Mass Flowmeter Junction Box.....	2-21
2-21. AC Wiring Terminals .....	2-22
2-22. AC Power Connections.....	2-22
2-23. DC Wiring Terminals .....	2-23
2-24. DC Power Connections.....	2-23
2-25. Load Resistance Versus Input Voltage.....	2-24
2-26. Isolated 4-20 Output Using External Power Supply.....	2-24
2-27. Non-Isolated 4-20 Output Using Input Power Supply.....	2-25
2-28. Isolated 4-20 Output Using Meter Power Supply (AC only) .....	2-25
2-29. Isolated Frequency Output Using External Power Supply ...	2-26
2-30. Non-Isolated Freq. Output Using Input Power Supply.....	2-26
2-31. Isolated Freq. Output Using Meter Power Sup. (AC only)...	2-26
2-32. Isolated Pulse Output Using External Power Supply .....	2-27
2-33. Non-Isolated Pulse Output Using Input Power Supply .....	2-27
2-34. Isolated Pulse Output Using Meter Power Sup. (AC only) ..	2-27

---

2-35.	Isolated Alarm Output Using External Power Supply .....	2-28
2-36.	Non-Isolated Alarm Output Using Meter Power Supply.....	2-28
2-37.	Isolated Alarm Output Using Meter Power Sup. (AC only)	2-29
2-38.	High Power Flow Meter Junction Box .....	2-29
2-39.	Optional Energy EMS RTD Input Wiring .....	2-30
2-40.	External 4-20 mA Input Wiring – External Power Supply...	2-31
2-41.	External 4-20 mA Input Wiring – DC Powered Meter.....	2-31
2-42.	External 4-20 mA Input Wiring – AC Powered Meter.....	2-32
2-43.	Optional External Contact Closure Input Wiring .....	2-32
3-1.	Flow Meter Display / Keypad.....	3-1
4-1.	Loop Powered Meter Wiring (HART).....	4-1
4-2.	DC Powered Meter Wiring (HART) .....	4-2
4-3.	AC Powered Meter Wiring (HART) .....	4-2
4-4.	RS-485 Wiring (MODBUS) .....	4-11

## Tables

1-1.	Measurable Range .....	1-4
4-1.	Byte Order (MODBUS).....	4-11
4-2.	Register Definitions (MODBUS) .....	4-13

## Warnings and Cautions



### Warning!

Agency approval for hazardous location installations varies between flow meter models. Consult the flow meter nameplate for specific flow meter approvals before any hazardous location installation.

Hot tapping must be performed by a trained professional, regulations often require a hot tap permit. The manufacturer of the hot tap equipment and/or the contractor performing the hot tap is responsible for providing proof of such a permit.

All flow meter connections, isolation valves and fittings for cold/hot tapping must have the same or higher pressure rating as the main pipeline.

For Pro-T™ Model insertion turbine flow meter installations, an insertion tool must be used for any installation where a flow meter is inserted under pressure greater than 50 psig.

To avoid serious injury, DO NOT loosen a compression fitting under pressure.

To avoid potential electric shock, follow National Electric Code or your local code when wiring this unit to a power source. Failure to do so could result in injury or death. All AC power connections must be in accordance with published CE directives. All wiring procedures must be performed with the power Off.

Before attempting any flow meter repair, verify that the line is not pressurized. Always remove main power before disassembling any part of the mass flow meter.



### Caution!

Calibration must be performed by qualified personnel. VorTek Instruments, Inc., strongly recommends that you return your flow meter to the factory for calibration.

In order to achieve accurate and repeatable performance, the flow meter must be installed with the specified minimum length of straight pipe upstream and downstream of the flow meter's sensor head.

When using toxic or corrosive gases, purge the line with inert gas for a minimum of four hours at full gas flow before installing the flow meter.

For Pro-T™ Model insertion turbine flow meter installations, the sensor alignment pointer must point downstream in the direction of flow.

The AC wire insulation temperature rating must meet or exceed 85°C (185°F).



## Revision History

### Rev. 02/2020 to 02/2021

<b>Page</b>	<b>Change Description</b>
0-1	Updated revision date
0-3	Updated copyright to 2021
B-1	Updated ATEX and IECEX labels
B-2	Updated declaration of conformity
C-4	Updated density calculation

## Chapter 1 Introduction

### Pro-T™ Multi-Variable Turbine Mass Flow Meters

The VorTek Instruments' Pro-T™ Insertion Turbine Flow Meters provide a reliable solution for process flow measurement. From a single entry point in the pipeline, Pro-T™ meters offer precise measurements of mass or volumetric flow rates.

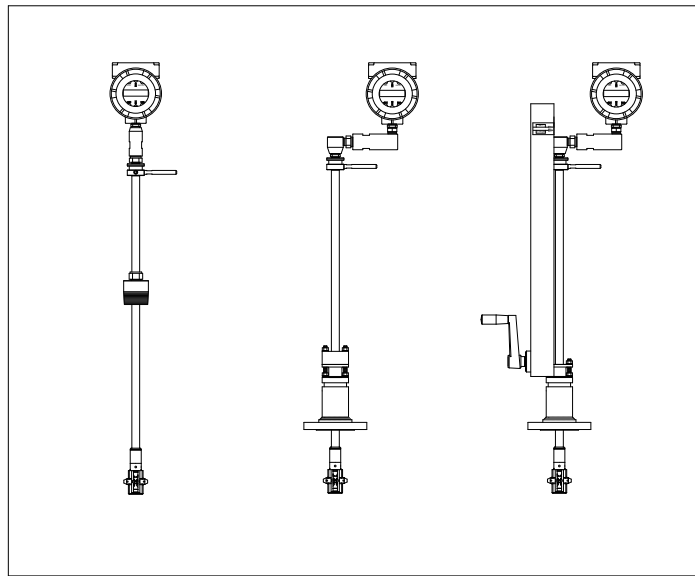

Figure 1-1. Insertion Turbine Multivariable Mass Flow Meters

#### Multi-Variable Mass Flow Meters

Mass flow meters utilize three primary sensing elements: a rotating turbine velocity sensor, an RTD temperature sensor, and a solid state pressure sensor to measure the mass flow rate of gases, liquids, and steam. Meters are available as loop powered devices or with up to three 4-20 mA analog output signals for monitoring your choice of the six process variables (energy flow, mass flow, volumetric flow, temperature, pressure and fluid density). The Energy Monitoring option permits real-time calculation of energy consumption for a facility or process.

#### Volumetric Flow Meters

The primary sensing element of a volumetric flow meter is a rotating turbine velocity sensor. Meters are loop powered. The analog 4-20 mA output signal offers your choice of volumetric or mass flow rate. Mass flow rate is based on a constant value for fluid density stored in the instrument's memory.

Both the mass and volumetric flow meters can be ordered with a local keypad/display which provides instantaneous flow rate, total, and process parameters in engineering units. A pulse output signal for remote totalization and MODBUS, HART, or BACnet communications are also available. Pro-T™ digital electronics allows for easy reconfiguration for most gases, liquids and steam. The VorTek Model Pro-T™ Meters' simple installation combines with an easy-to-use interface that provides quick set up, long term reliability and accurate mass flow measurement over a wide range of flows, pressures and temperatures.

### ***Using This Manual***

This manual provides information needed to install and operate the Pro-T™ Insertion Turbine Flow Meters.

- Chapter 1 includes the introduction and product description
- Chapter 2 provides information needed for installation
- Chapter 3 describes system operation and programming
- Chapter 4 information on HART, MODBUS, and BACnet protocols
- Chapter 5 covers troubleshooting and repair

Appendix A - Product Specifications, Appendix B – Flow Meter Calculations, Appendix C – Glossary of Terms

## Note and Safety Information

We use note, caution and warning statements throughout this book to draw your attention to important information.



### Warning!

This statement appears with information that is important to protect people and equipment from damage. Pay very close attention to all warnings that apply to your application.



### Caution!

This statement appears with information that is important for protecting your equipment and performance. Read and follow all cautions that apply to your application.



### Note

This statement appears with a short message to alert you to an important detail.

## Receipt of System Components

When receiving a VorTek mass flow meter, carefully check the outside packing carton for damage incurred in shipment. If the carton is damaged, notify the local carrier and submit a report to the factory or distributor. Remove the packing slip and check that all ordered components are present. Make sure any spare parts or accessories are not discarded with the packing material. Do not return any equipment to the factory without first contacting VorTek Customer Service.

## Technical Assistance

If you encounter a problem with your flow meter, review the configuration information for each step of the installation, operation and set up procedures. Verify that your settings and adjustments are consistent with factory recommendations. Refer to Chapter 5, Troubleshooting, for specific information and recommendations.

If the problem persists after following the troubleshooting procedures outlined in Chapter 5, contact VorTek Instruments, Technical Support at (888) 386-7835 or (303) 682-9999 between 8:00 a.m. and 5:00 p.m. MST. When calling Technical Support, have the following information on hand:

- the serial number and VorTek order number (all marked on the meter nameplate)
- the problem you are encountering and any corrective action taken
- application information (fluid, pressure, temperature and piping configuration)

## How the Pro-T™ Turbine Mass Flow Meter Operates

VorTek Model Pro-T™ Multivariable Insertion Turbine Mass Flow Meters are designed to monitor mass flow rate by directly measuring three variables—fluid velocity, temperature and pressure. The built-in flow computer calculates the mass flow rate and volumetric flow rate based on these three direct measurements. To measure fluid velocity, the flow meter incorporates a rotating turbine in the flow stream. The rotation is converted into an electrical output which is proportional to fluid velocity. Temperature is measured using a platinum resistance temperature detector (PRTD) and pressure measurement is achieved using a solid-state pressure transducer.

### Velocity Measurement

Fluid passing through the turbine causes its rotor to spin. The rotor is fabricated from 17-4PH stainless steel which is slightly magnetic, and is positioned in close proximity to a passive magnetic pickup coil. As each blade rotates by the pickup coil, a small sinusoidal voltage is generated. This sinusoidal voltage is then amplified, filtered, and shaped by the measurement electronics. The frequency of the signal is proportional to the flowing velocity.

### Flow Velocity Range

To ensure trouble-free operation, turbine flow meters must be correctly sized so that the flow velocity range through the meter lies within the measurable velocity range.

The measurable range is defined by the minimum and maximum velocity using the following table.

Gas or Steam				
	Minimum Velocity		Maximum Velocity	
	(ft/sec)	(m/sec)	(ft/sec)	(m/sec)
<b>R40</b>	3.5	1.07	43.0	13.11
<b>R30</b>	4.0	1.22	62.5	19.05
<b>R25</b>	5.0	1.52	80.0	24.38
<b>R20</b>	7.0	2.13	100.0	30.48
<b>R15</b>	8.5	2.59	134.6	41.03
<b>R10</b>	12.0	3.66	205.0	62.48

Table 1-1 Measurable Range

The pressure drop for Model Pro-T™ insertion meters is negligible.

## ***Temperature Measurement***

Pro-T Flow Meters use a 1000 ohm platinum resistance temperature detector (PRTD) to measure fluid temperature.

## ***Pressure Measurement***

Pro-T Flow Meters incorporate a solid-state pressure transducer isolated by a 316L stainless steel diaphragm. The transducer itself is micro-machined silicon, fabricated using integrated circuit processing technology. A nine-point pressure/temperature calibration is performed on every sensor. Digital compensation allows these transducers to operate within a 0.3% of full scale accuracy band within the entire ambient temperature range of -40°F to 140°F (-40 to 60°C). Thermal isolation of the pressure transducer ensures the same accuracy across the allowable process fluid temperature range of -200°F to 750°F (-128 to 400°C).

## ***Flow Meter Configuration***

The Pro-T™ Insertion Turbine Mass Flow Meter has a sensing head which contains the turbine rotor, temperature sensor, and pressure tap. The pressure sensor is located in the pressure transducer housing between the stem and electronics housing.

The meter is installed through a full port block valve and mounting adapter having a clear, cylindrical port diameter of 1.875" diameter. It can be installed during system downtime or using standard "Hot Tap" procedures.

The meter directly monitors the velocity at a point in the cross-sectional area of a pipe, duct, or stack. The velocity at a point in the pipe varies as a function of the Reynolds number. When a fluid flows through a pipe, the velocity generated is not constant across the diameter. The fluid velocity varies across the diameter of the pipe creating a "Velocity Profile". That is, velocities near the center of the pipe are faster than those nearer to the wall. In addition, the velocity profile varies in concert with flow rate from the lowest to the highest flows. Mathematical descriptions of this profile have been developed for over 100 years. By knowing the velocity profile and the flow rate at a single point, the average flow rate can be determined. The accuracy of the flow rate computation depends on adherence to the piping installation requirements given in Chapter 2. If adherence to those guidelines cannot be met, contact the factory for specific installation advice.

## ***Multivariable Options***

The Pro-T™ model is available with the following options: V, volumetric flowmeter; VT, velocity and temperature sensors; VTP, velocity, temperature, and pressure sensors; VT-EM energy output options; VTP-EM, energy options with pressure; VT-EP, external pressure transmitter input.

### ***Line Size / Process Connections***

The Pro-T™ Insertion model can be used in line sizes 3 inch and greater and is built with a compression fitting or packing gland design using 2 inch NPT, or 2 inch flanged connections (ANSI 150, 300, 600, 900, PN16, 40, 63, JIS 10K, 20K, 30K flanges). The packing gland design can be ordered with a permanent or removable retractor.

### ***Flow Meter Electronics***

Pro-T™ Flow Meter electronics are available mounted directly to the flow meter, or remotely mounted. The electronics housing may be used indoors or outdoors, including wet environments. Available input power options are: DC loop powered (2-wire), DC powered, or AC powered. Three analog output signals are available for your choice of three of the six process variables: energy flow rate, mass flow rate, volumetric flow rate, temperature, pressure or fluid density. A pulse output signal for remote totalization and MODBUS, HART, and BACnet communications are also available.

Pro-T™ Flow Meters include a local 2 x 16 character LCD display housed within the enclosure. Local operation and reconfiguration is accomplished using six pushbuttons operated via finger touch. For hazardous locations, the six buttons can be operated with the electronics enclosure sealed using a hand-held magnet, thereby not compromising the integrity of the hazardous location certification.

The electronics include nonvolatile memory that stores all configuration information. The nonvolatile memory allows the flow meter to function immediately upon power up, or after an interruption in power. All flowmeters are calibrated. The instrument is configured for the customer's flow application.

## Chapter 2 Installation

### Installation Overview

VorTek's Pro-T™ Insertion Turbine Flow Meter installations are simple and straightforward. After reviewing the installation requirements given below, see page 2-3 for Pro-T™ installation instructions. Wiring instructions begin on page 2-16.

### Flow Meter Installation Requirements

Before installing the flow meter, verify the installation site allows for these considerations:

1. Line pressure and temperature will not exceed the flow meter rating.
2. The location meets the required minimum number of pipe diameters upstream and downstream of the sensor head as illustrated in Figure 2-1.
3. Safe and convenient access with adequate overhead clearance for maintenance purposes.
4. Verify that the cable entry into the instrument meets the specific standard required for hazardous area installations. The cable entry device shall be of a certified flameproof type, suitable for the conditions of use and correctly installed. The degree of protection of at least IP66 to EN 60529 is only achieved if certified cable entries are used that are suitable for the application and correctly installed. Unused apertures shall be closed with suitable blanking elements.
5. For remote installations, verify the supplied cable length is sufficient to connect the flow meter sensor to the remote electronics.

Also, before installation check your flow system for anomalies such as:

- leaks
- valves or restrictions in the flow path that could create disturbances in the flow profile that might cause unexpected flow rate indications
- avoid areas where high RF, EMI, or other electrical interference may be present. Devices such as VFD's (variable frequency drives), large AC motors, etc.



**Warning!**

Consult the flow meter nameplate for specific flow meter approvals before any hazardous location installation.



### Unobstructed Flow Requirements

Select an installation site that will minimize possible distortion in the flow profile. Valves, elbows, control valves and other piping components may cause flow disturbances. Check your specific piping condition against the examples shown below. In order to achieve accurate and repeatable performance install the flow meter using the recommended number of straight run pipe diameters upstream and downstream of the sensor.

Note: For liquid applications in vertical pipes, avoid installing with flow in the downward direction because the pipe may not be full at all points. Choose to install the meter with flow in the upward direction if possible.

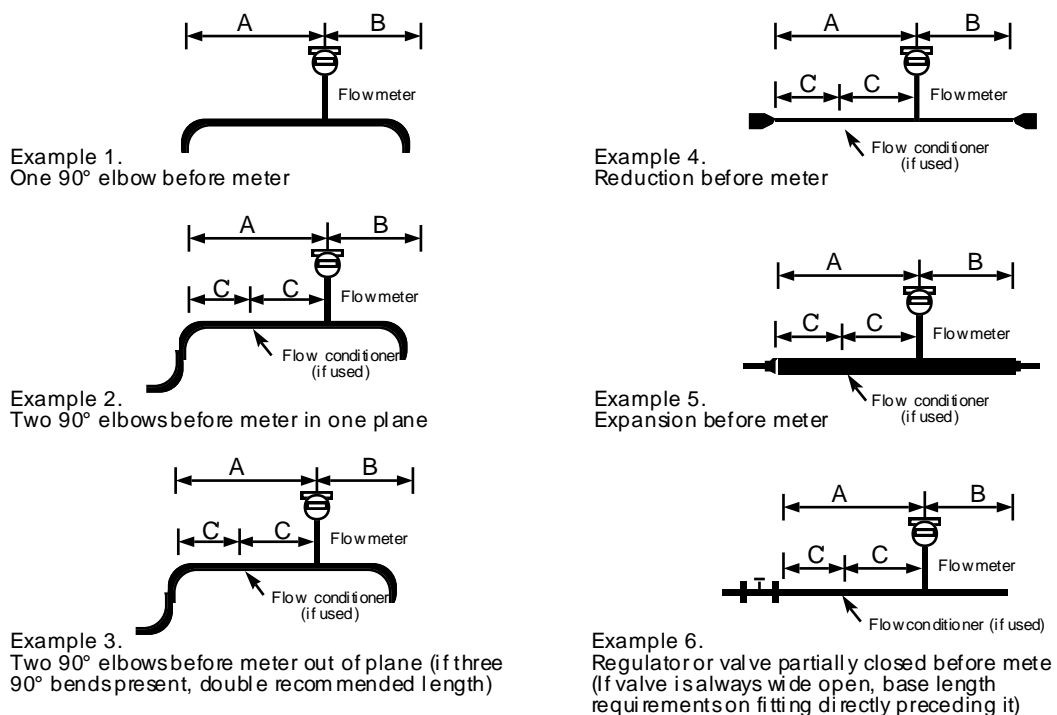

Example	Minimum Required Upstream Diameters				Minimum Required Downstream Diameters	
	No Flow Conditioner	With Flow Conditioner			No Flow Conditioner	With Flow Conditioner
	A	A	C	C'	B	B
1	10 D	N/A	N/A	N/A	5 D	5 D
2	15 D	10 D	5 D	5 D	5 D	5 D
3	30 D	10 D	5 D	5 D	10 D	5 D
4	10 D	10 D	5 D	5 D	5 D	5 D
5	20 D	10 D	5 D	5 D	5 D	5 D
6	30 D	10 D	5 D	5 D	10 D	5 D

D = Internal diameter of channel. N/A = Not applicable

Figure 2-1. Recommended Pipe Length Requirements for Installation

## Insertion Flow Meter Installation

Prepare the pipeline for installation using either a cold tap or hot tap method described on the following pages. Refer to a standard code for all pipe tapping operations. The following tapping instructions are general in nature and intended for guideline purposes only. Before installing the meter, review the mounting position and isolation valve requirements given below.

### Mounting Position

Allow clearance between the electronics enclosure top and any other obstruction when the meter is fully retracted.

### Isolation Valve Selection

An isolation valve is available as an option with Pro-T™ meters. If you supply the isolation valve, it must meet the following requirements:

1. A minimum valve bore diameter of 1.875 inches is required, and the valve's body size should be two inches. Normally, gate valves are used.
2. Verify that the valve's body and flange rating are within the flow meter's maximum operating pressure and temperature.
3. Choose an isolation valve with at least two inches existing between the flange face and the gate portion of the valve. This ensures that the flow meter's sensor head will not interfere with the operation of the isolation valve.

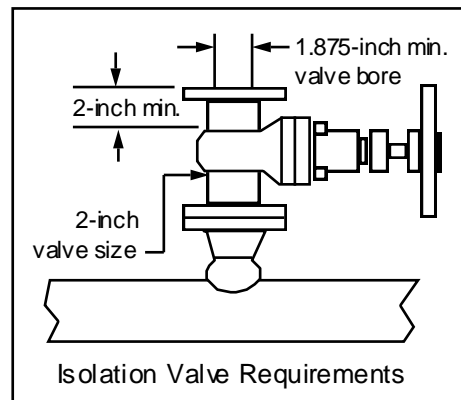

## Cold Tap Guidelines

Refer to a standard code for all pipe tapping operations. The following tapping instructions are general in nature and intended for guideline purposes only.



### Caution!

When using toxic or corrosive gases, purge the line with inert gas for a minimum of four hours at full gas flow before installing the flow meter.



### Warning!

All flow meter connections, isolation valves and fittings for cold tapping must have the same or higher pressure rating as the main pipeline.

1. Turn off the flow of process gas, liquid or steam. Verify that the line is not pressurized.
2. Confirm that the installation site meets the minimum upstream and downstream pipe diameter requirements. See Figure 2-1.
3. Use a cutting torch or sharp cutting tool to tap into the pipe. The pipe opening must be at least 1.875 inches in diameter. (Do not attempt to insert the sensor probe through a smaller hole.)
4. Remove all burrs from the tap. Rough edges may cause flow profile distortions that could affect flow meter accuracy. Also, obstructions could damage the sensor assembly when inserting into the pipe.
5. After cutting, measure the thickness of the cut-out and record this number for calculating the insertion depth.

6. Weld the flow meter pipe connection on the pipe. Make sure this connection is within  $\pm 5^\circ$  perpendicular to the pipe centerline.

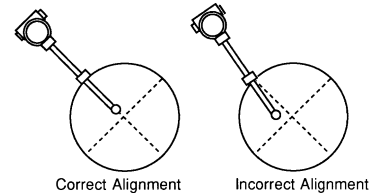

7. Install the isolation valve (if used).
8. When welding is complete and all fittings are installed, close the isolation valve or cap the line. Run a static pressure check on the welds. If pressure loss or leaks are detected, repair the joint and re-test.
9. The first time the sensor is inserted, install the check-disc tool on the flow meter rather than the rotor.
10. Open the isolation valve (if used) and insert the check-disc tool. After successful insertion, retract the sensor and remove the flow meter.
11. Install the rotor and connect the meter to the pipe process connection.
12. Calculate the sensor probe insertion depth and insert the sensor probe into the pipe as described on the following pages.

## Hot Tap Guidelines



### Warning!

Hot tapping must be performed by a trained professional. US. regulations often require a hot tap permit. The manufacturer of the hot tap equipment and/or the contractor performing the hot tap is responsible for providing proof of such a permit.



### Warning!

All flow meter connections, isolation valves, and fittings for hot tapping must have the same or higher pressure rating as the main pipeline.

Refer to a standard code for all pipe tapping operations. The following tapping instructions are general in nature and intended for guideline purposes only.

1. Confirm that the installation site meets the minimum upstream and downstream pipe diameter requirements.
2. Weld a two inch mounting adapter on the pipe. Make sure the mounting adapter is within  $\pm 5^\circ$  perpendicular to the pipe centerline (see previous page). The pipe opening must be at least 1.875 inches in diameter.
3. Connect a two inch process connection on the mounting adapter.
4. Connect an isolation valve on the process connection. The valve's full open bore must be at least 1.875 inches in diameter.
5. Run a static pressure check on the welds. If pressure loss or leaks are detected, repair the joint and re-test.
6. Connect the hot tapping equipment to the isolation valve, open the isolation valve and drill at least a 1.875 inch diameter hole.
7. Retract the drill, close the isolation valve, and remove the hot tapping equipment.
8. The first time the sensor is installed, install the check-disc tool on the flow meter rather than the rotor.
9. Open the isolation valve and insert the check-disc tool. After successful insertion, retract the sensor, close the isolation valve and remove the flow meter.
10. Install the rotor, connect the flow meter to the isolation valve and open the isolation valve.
11. Calculate the sensor probe insertion depth and insert the sensor probe into the pipe as described on the following pages.

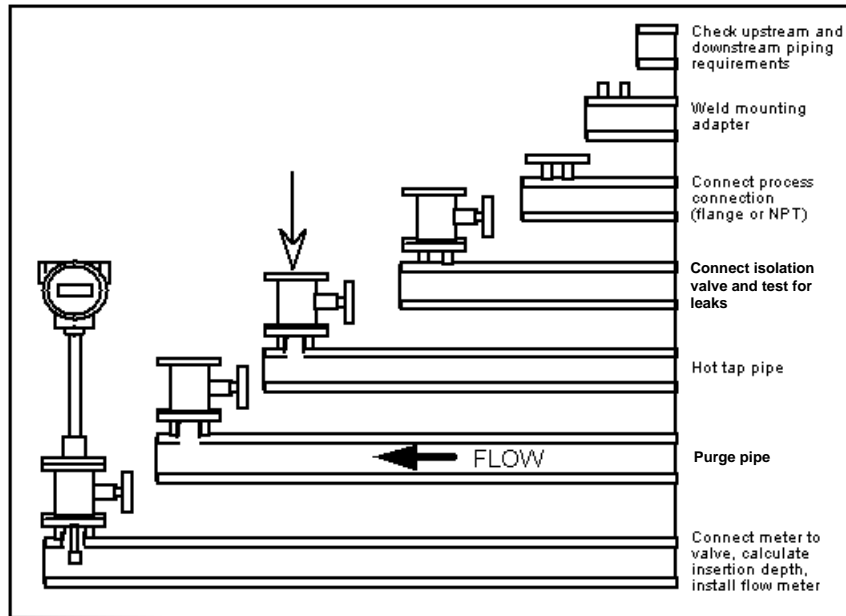

Figure 2-2. Hot Tap Sequence

## Flow Meter Insertion

The sensor head must be properly positioned in the pipe. For this reason, it is important that insertion length calculations are carefully followed. A sensor probe inserted at the wrong depth in the pipe will result in inaccurate readings.

Insertion turbine flow meters are applicable to pipes 3 inches and larger. For pipe sizes 10 inches and smaller, the centerline of the meter's sensing head is located at the pipe's centerline. For pipe sizes larger than 10 inches, the centerline of the sensing head is located 5 inches from the inside wall of the pipe.

Insertion flow meters are available in three probe lengths:

*Standard Probe* configuration is used with most flow meter process connections. The length, S, of the stem is 28.67 inches.

*Compact Probe* configuration is used with compression fitting process connections. The length, S, of the stem is 12.3 inches.

*12-Inch Extended Probe* configuration is used with exceptionally lengthy flow meter process connections. The length, S, of the stem is 40.67 inches.

### Use the Correct Insertion Formula

Depending on your flow meter's process connection, use the applicable insertion length formula and installation procedure as follows:

- Flow meters with a compression type connection (NPT or flanged) follow the instructions beginning on page 2-8.
- Flow meters with a packing gland type connection (NPT or flanged) configured with an insertion tool, follow the instructions beginning on page 2-10.
- Flow meters with a packing gland type connection (NPT or flanged) without an insertion tool, follow the instructions beginning on page 2-13.



#### Warning!

An insertion tool must be used for any installation where a flow meter is inserted under pressure greater than 50 psig.

### Installing Flow Meters with a Compression Connection\*

Use the following formula to determine insertion length for flow meters (NPT and flanged) with a compression process connection. The installation procedure is given on the next page.

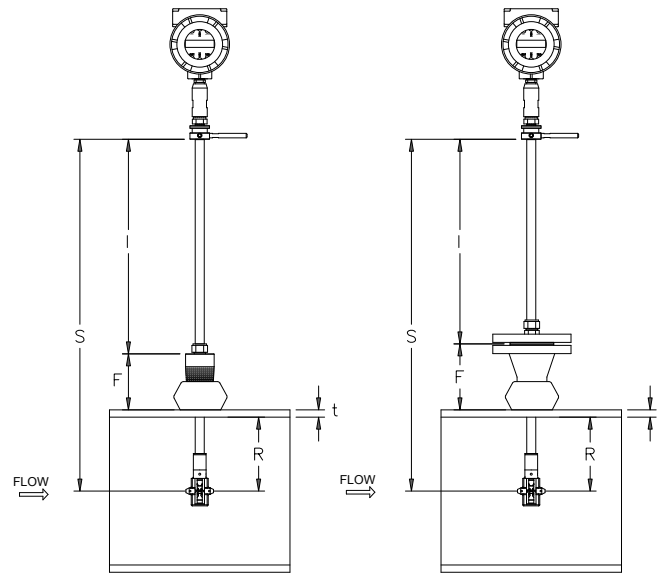

#### Insertion Length Formula

$$I = S - F - R - t$$

Where:

I = Insertion length.

S = Stem length – the distance from the center of the sensor head to the base of the enclosure adapter (S = 28.67 inches for standard probes; S = 12.3 inches for compact; S = 40.67 inches for 12-inch extended).

F = Distance from the raised face of the flange or top of NPT stem housing to the outside of the pipe wall.

R = Pipe inside diameter ÷ 2 for pipes ten inches and smaller.

R = Five inches for pipe diameters larger than ten inches.

t = Thickness of the pipe wall. (Measure the disk cut-out from the tapping procedure or check a piping handbook for thickness.)

Figure 2-3. Insertion Calculation (Compression Type)

#### Example:

To install a Pro-T™ meter with a standard probe (S = 28.67 inches) into a 14 inch schedule 40 pipe, the following measurements are taken:

$$F = 3 \text{ inches}$$

$$R = 5 \text{ inches}$$

$$t = 0.438 \text{ inches}$$

The insertion length for this example is 20.23 inches. Insert the stem through the fitting until an insertion length of 20.23 inches is measured with a ruler.

\*All dimensions are in inches

## Insertion Procedure for Meters with a Compression Connection

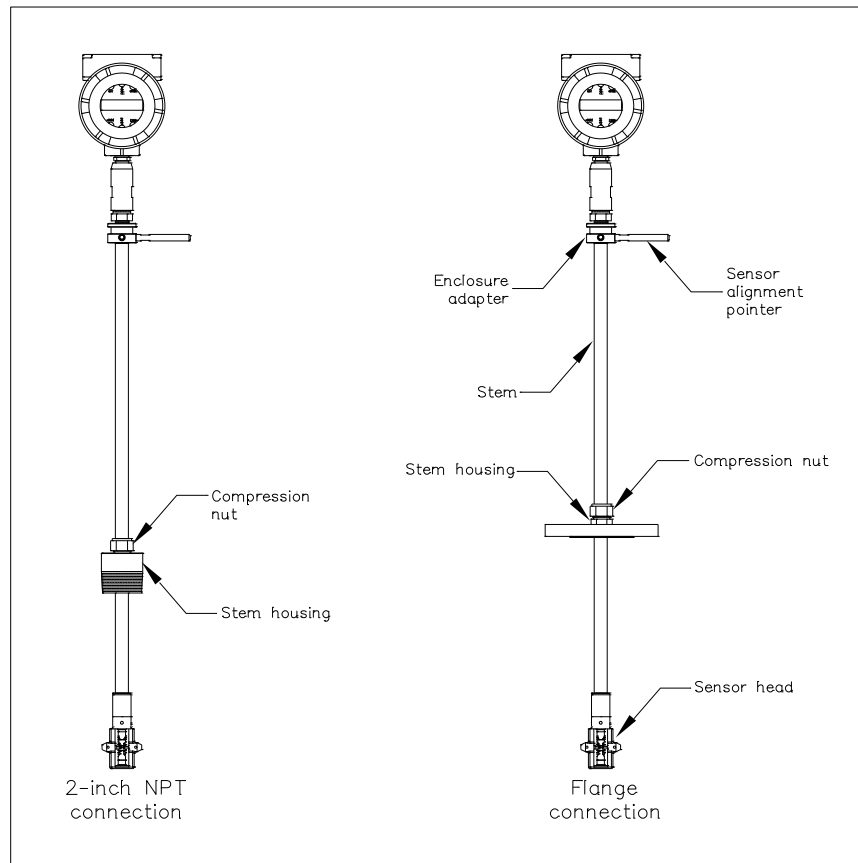

Figure 2-4. Flow Meter with Compression Type Fitting



### Caution!

The sensor alignment pointer must point downstream, in the direction of flow.



### Warning!

To avoid serious injury, DO NOT loosen the compression fitting under pressure.

1. Calculate the required sensor probe insertion length.
2. Fully retract the stem until the sensor head is touching the bottom of the stem housing. Slightly tighten the compression nut to prevent slippage.
3. Bolt or screw the flow meter assembly into the process connection. Use Teflon tape or pipe sealant to improve the seal and prevent seizing on NPT styles.
4. Hold the meter securely while loosening the compression fitting. Insert the sensor into the pipe until the calculated insertion length,  $I$ , is measured between the base of the enclosure adapter and the top of the stem housing, or to the raised face of the flanged version. Do not force the stem into the pipe.
5. Align the sensor head using the sensor alignment pointer. Adjust the alignment pointer parallel to the pipe and pointing downstream.
6. Tighten the compression fitting to lock the stem in position. **When the compression fitting is tightened, the position is permanent.**



### Installing Flow Meters with a Packing Gland Connection\*

Use the formula below to determine the insertion depth for flow meters (NPT and flanged) equipped with an insertion tool. To install, see the next page for instructions for meters with a permanent insertion tool. For meters with a removable insertion tool, see page 2-12.

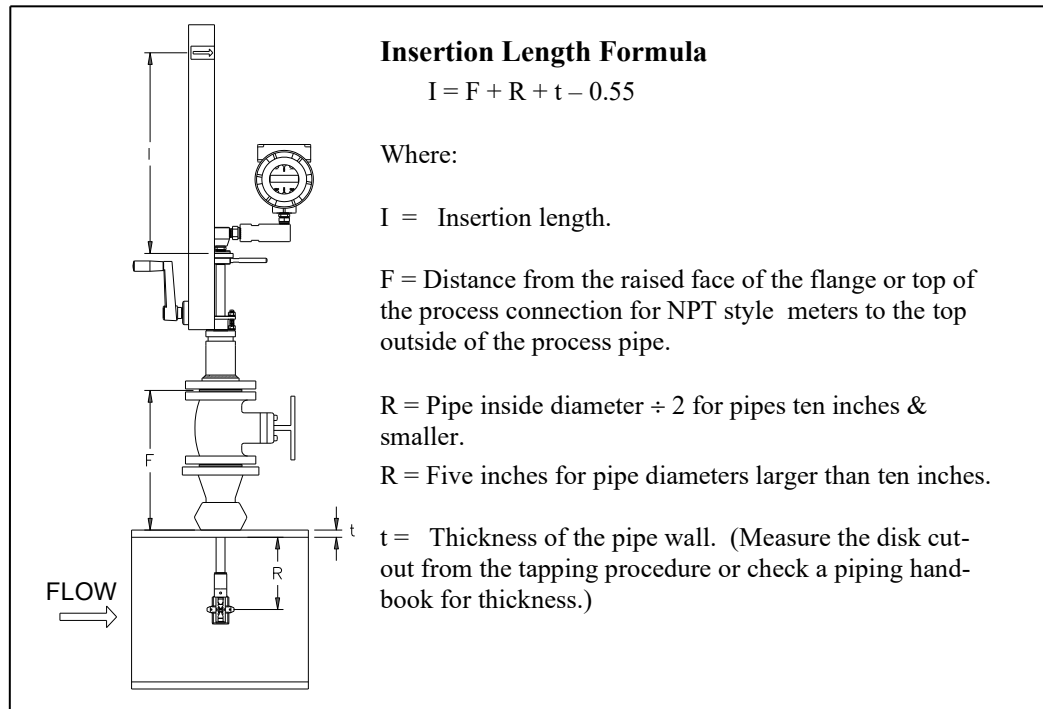

Figure 2-5. Insertion Calculation (Meters with Insertion Tool)

#### Example 1: Flange Style Meters:

To install a Pro-T™ flow meter into a 14 inch schedule 40 pipe, the following measurements are taken:

$$\begin{aligned} F &= 12 \text{ inches} \\ R &= 5 \text{ inches} \\ t &= 0.438 \text{ inches} \end{aligned}$$

The example insertion length is 16.89 inches.

#### Example 2: NPT Style Meters:

The length of thread engagement on the NPT style meters is also subtracted in the equation. The length of the threaded portion of the NPT meter is 1.18 inches. Measure the thread portion still showing after the installation and subtract that amount from 1.18 inches. This gives you the thread engagement length. If this cannot be measured use .55 inch for this amount.

$$\begin{aligned} F &= 12 \text{ inches} \\ R &= 5 \text{ inches} \\ t &= 0.438 \text{ inches} \end{aligned}$$

The example insertion length is 16.34 inches.

\*All dimensions are in inches.

## Insertion Procedure for Flow Meters with Permanent Insertion Tool

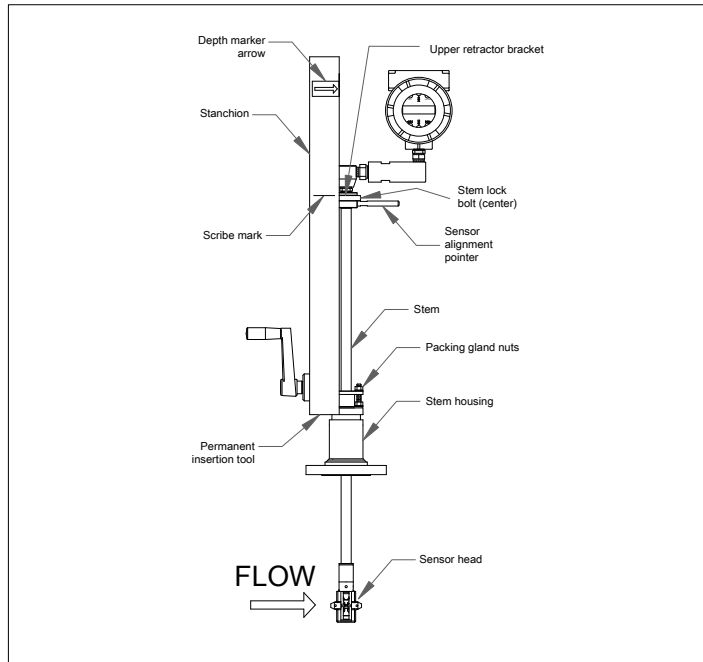

Figure 2-6. Flow Meter with Permanent Insertion Tool



### Caution!

The sensor alignment pointer must point downstream, in the direction of flow.



### Note

If line pressure is above 500 psig, it could require up to 25 ft lb of torque to insert the flow meter. Do not confuse this with possible interference in the pipe.

1. Calculate the required sensor probe insertion length (see previous page). Measure from the depth marker arrow down the stanchion and scribe a mark at the calculated insertion depth.
2. Fully retract the flow meter until the sensor head is touching the bottom of the stem housing. Attach the meter assembly to the two inch full-port isolation valve, if used. Use Teflon tape or pipe sealant to improve seal and prevent seizing on NPT style.
3. Loosen the two packing gland nuts on the stem housing of the meter. Loosen the stem lock bolt adjacent to the sensor alignment pointer. Align the sensor head using the sensor alignment pointer. Adjust the alignment pointer parallel to the pipe and pointing downstream. Tighten the stem lock bolt to secure the sensor position.
4. Slowly open the isolation valve to the full open position. If necessary, slightly tighten the two packing gland nuts to reduce the leakage around the stem.
5. Turn the insertion tool handle clockwise to insert the sensor head into the pipe. Continue until the top of the upper retractor bracket aligns with the insertion length position scribed on the stanchion. Do not force the stem into the pipe.
6. Tighten the packing gland nuts to stop leakage around the stem. Do not torque over 20 ft-lb.

## Insertion Procedure for Flow Meters with Removable Insertion Tool

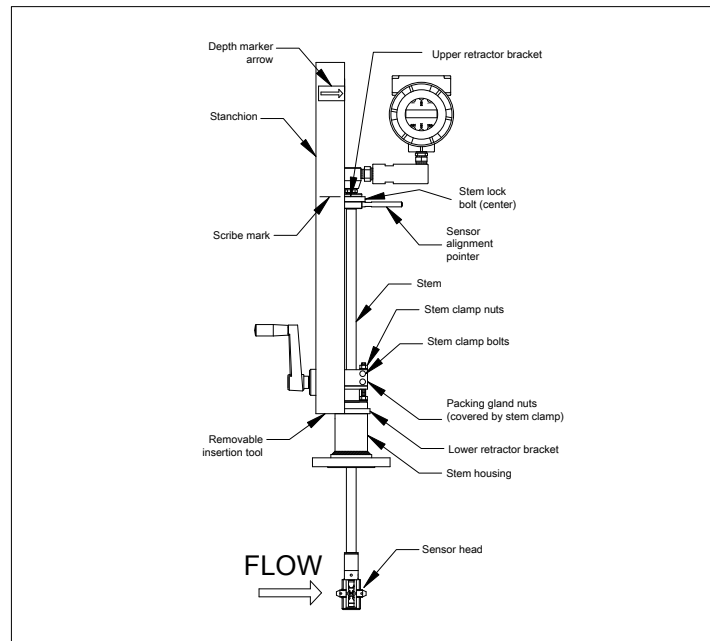

Figure 2-7. Flow Meter with Removable Insertion Tool



### Caution!

The sensor alignment pointer must point downstream, in the direction of flow.



### Note

If line pressure is above 500 psig, it could require up to 25 ft lb of torque to insert the flow meter. Do not confuse this with possible interference in the pipe.

1. Calculate the required sensor probe insertion length. Measure from the depth marker arrow down the stanchion and scribe a mark at the calculated insertion depth.
2. Fully retract the flow meter until the sensor head is touching the bottom of the stem housing. Attach the meter assembly to the two inch full-port isolation valve, if used. Use Teflon tape or pipe sealant to improve seal and prevent seizing on NPT style.
3. Remove the two top stem clamp nuts and loosen two stem clamp bolts. Slide the stem clamp away to expose the packing gland nuts.
4. Loosen the two packing gland nuts. Loosen the stem lock bolt adjacent to the sensor alignment pointer. Align the sensor head using the sensor alignment pointer. Adjust the alignment pointer parallel to the pipe and pointing downstream. Tighten the stem lock bolt to secure the sensor position.
5. Slowly open the isolation valve to the full open position. If necessary, slightly tighten the two packing gland nuts to reduce the leakage around the stem.
6. Turn the insertion tool handle clockwise to insert the stem into the pipe. Continue until the top of the upper retractor bracket lines up with the insertion length mark scribed on the stanchion. Do not force the stem into the pipe.

7. Tighten the packing gland nuts to stop leakage around the stem. Do not torque over 20 ft-lbs.
8. Slide the stem clamp back into position. Torque stem clamp bolts to 15 ft-lbs. Replace the stem clamp nuts and torque to 10-15 ft-lbs.
9. To separate the insertion tool from the flow meter, remove four socket head cap bolts securing the upper and lower retractor brackets. Remove the insertion tool.

### **Installation of Meters with Packing Gland Connection (No Insertion Tool)\***

Use the following formula to determine insertion depth for meters with a packing gland connection (NPT and flanged) without an insertion tool.

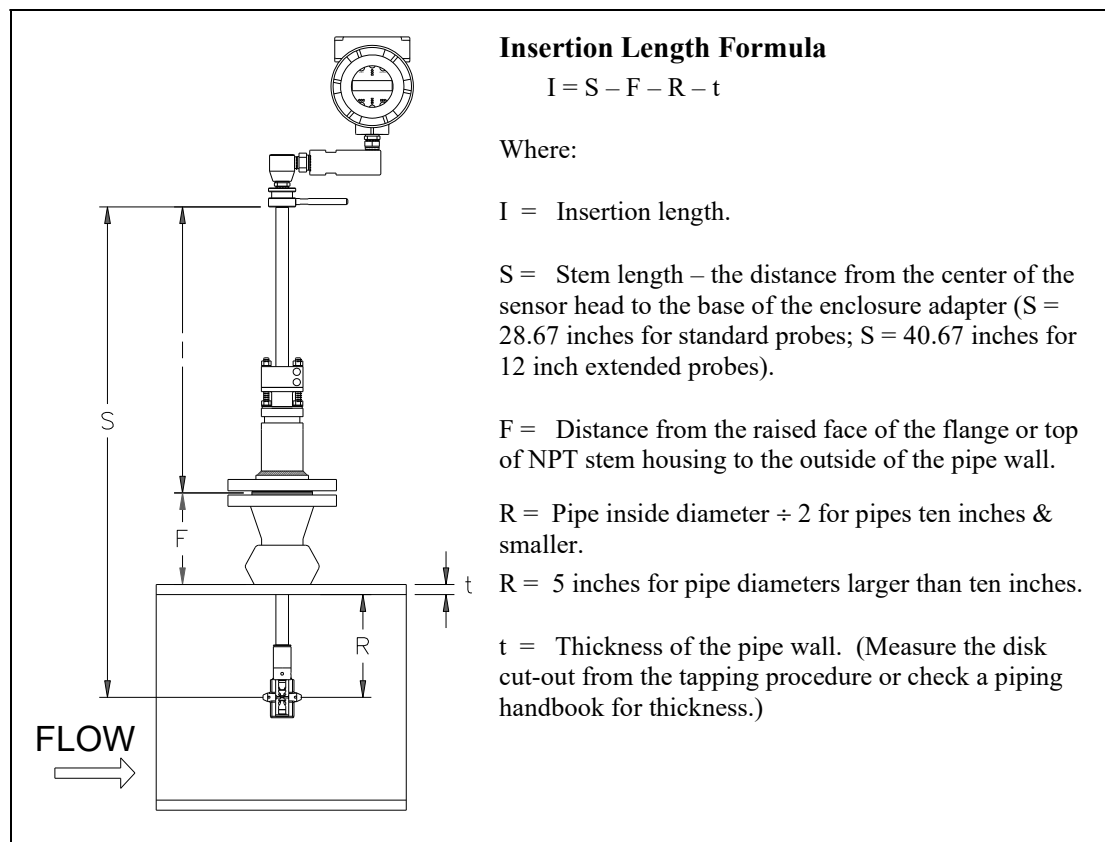

Figure 2-8. Insertion Calculation (Meters without Insertion Tool)

#### **Example:**

To install a Pro-T™ flow meter with a standard probe (S = 28.67) into a 14 inch schedule 40 pipe, the following measurements are taken:

$$\begin{aligned} F &= 3 \text{ inches} \\ R &= 5 \text{ inches} \\ t &= 0.438 \text{ inches} \end{aligned}$$

The example insertion length is 20.23 inches.

*\*All dimensions are in inches.*

## Insertion Procedure for Flow Meters with No Insertion Tool (Packing Gland Connection)

**Warning!**

The line pressure must be less than 50 psig for installation.

**Caution!**

The sensor alignment pointer must point downstream, in the direction of flow.

1. Calculate the required sensor probe insertion length.
2. Fully retract the stem until the sensor head is touching the bottom of the stem housing. Remove the two top stem clamp nuts and loosen two stem clamp bolts. Slide the stem clamp away to expose the packing gland nuts. Loosen the two packing gland nuts.
3. Align the sensor head using the sensor alignment pointer. Adjust the alignment pointer parallel to the pipe and pointing downstream.
4. Insert the sensor head into the pipe until insertion length,  $I$ , is achieved. Do not force the stem into the pipe.
5. Tighten the packing gland nuts to stop leakage around the stem. Do not torque over 20 ft-lbs.
6. Slide the stem clamp back into position. Torque stem clamp bolts to 15 ft-lbs. Replace the stem clamp nuts and torque to 10-15 ft-lbs.

## Display/Keypad Adjustment (All Meters)

The orientation of the display / keypad may be changed in 90 degree increments for easier viewing.

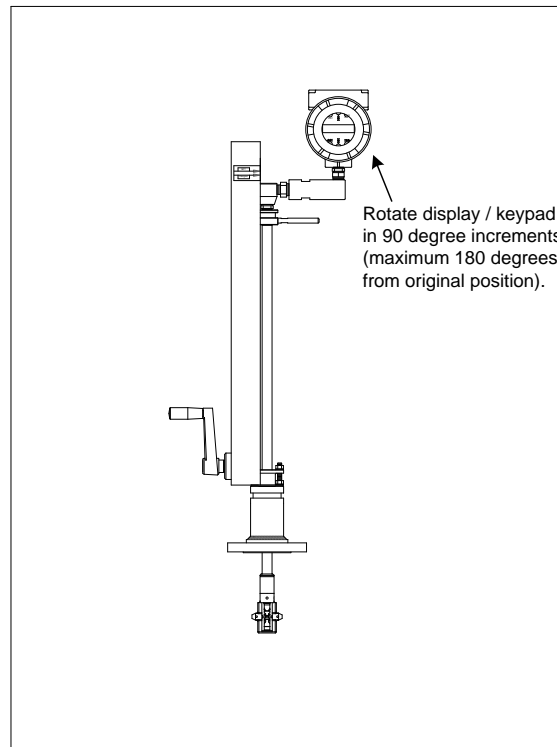

Figure 2-9. Display/Keypad Viewing Adjustment

The electronics boards are electro-statically sensitive. Wear a grounding wrist strap and make sure to observe proper handling precautions required for static-sensitive components. To adjust the display:

1. Disconnect power to the flow meter.
2. Loosen the small set screw which secures the electronics enclosure cover. Unscrew and remove the cover.
3. Loosen the 4 captive screws.
4. Carefully pull the display/microprocessor board away from the meter standoffs. Make sure not to damage the connected ribbon cable.
5. Rotate the display/microprocessor board to the desired position. Maximum turn, two positions left or two positions right (180-degrees).
6. Align the board with the captive screws. Check that the ribbon cable is folded neatly behind the board with no twists or crimps.
7. Tighten the screws. Replace the cover and set screw. Restore power to the meter.

## Loop Power Flow Meter Wiring Connections



### Warning!

To avoid potential electric shock, follow National Electric Code safety practices or your local code when wiring this unit to a power source and to peripheral devices. Failure to do so could result in injury or death. All wiring procedures must be performed with the power off.

Use a Class 2 isolated power supply that is grounded, provides DC output, and has no more than 10% output ripple.

A power switch is not provided with this meter, an approved switch meeting the power requirements listed in Appendix A must be provided by the user. It must be easily accessible and marked as the disconnect for the flow meter.

Only the connectors supplied with the meter are to be used for connecting wiring.

If the equipment is used in a manner not specified the protection provided by the equipment may be impaired.

The NEMA 4X enclosure contains an integral wiring compartment located in the smaller end of the enclosure. Two 3/4-inch female NPT conduit entries are available for separate power and signal wiring. For all hazardous area installations, only suitable certified cable glands, blanking plugs or thread adapters may be used. The cable entry device shall be of a certified flameproof type, suitable for the conditions of use and correctly installed. The degree of protection of at least IP66 to EN 60529 is only achieved if certified cable entries are used that are suitable for the application and correctly installed. Unused apertures shall be closed with suitable blanking elements. If conduit seals are used, they must be installed within 18 inches (457 mm) of the enclosure.

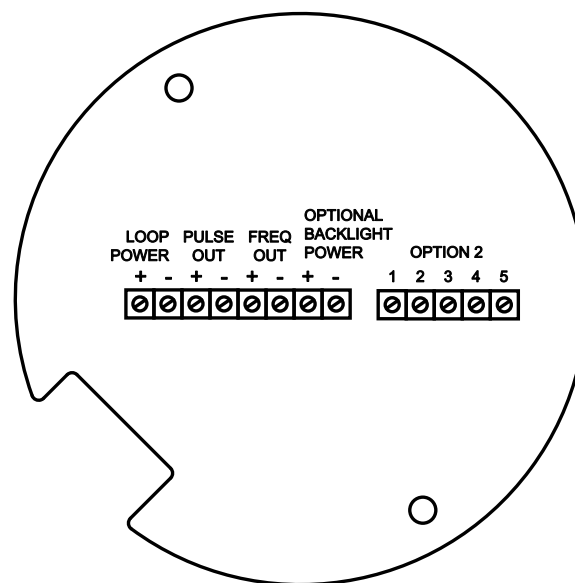

Figure 2-10. Loop Power Wiring Terminals

## Input Power Connections

To access the wiring terminal blocks, locate and loosen the small set screw which locks the small enclosure cover in place. Unscrew the cover to expose the terminal block.

### DC Power Wiring

Connect 4-20 mA loop power (12 to 36 VDC at 25 mA, 1W max.) to the +Loop Power and -Loop Power terminals on the terminal block. Torque all connections to 4.43 to 5.31 in-lbs (0.5 to 0.6 Nm). The DC power wire size must be 20 to 12 AWG with the wire stripped 1/4 inch (7 mm).



### Caution!

The DC wire insulation temperature rating must meet or exceed 85°C (185°F), maximum operating voltage 300 VRMS.

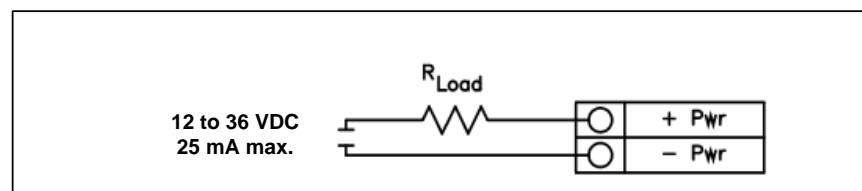

Figure 2-11. DC Power Connections

### 4-20 mA Output Connections

The Pro-T™ meter has a single 4-20 mA loop. The 4-20 mA loop current is controlled by the meter electronics. The electronics must be wired in series with the sense resistor or current meter. The current control electronics require 12 volts at the input terminals to operate correctly.

The maximum loop resistance (load) for the current loop output is dependent upon the supply voltage and is given in Figure 2-12. The 4-20 mA loop is optically isolated from the flow meter electronics.

$R_{load}$  is the total resistance in the loop, including the wiring resistance ( $R_{load} = R_{wire} + R_{sense}$ ). To calculate  $R_{max}$ , the maximum  $R_{load}$  for the loop, subtract the minimum terminal voltage from the supply voltage and divide by the maximum loop current, 20 mA. Thus:

$$\text{The maximum resistance } R_{load} = R_{max} = (V_{supply} - 12V) / 0.020 \text{ A}$$

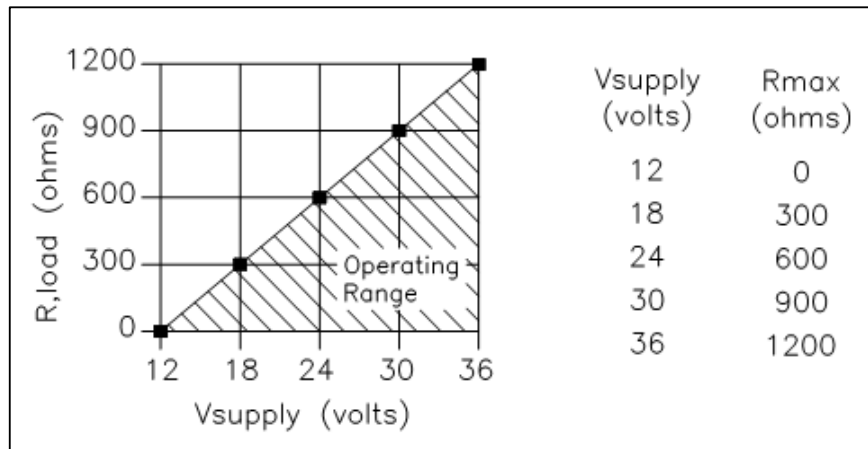

Figure 2-12. Load Resistance Versus Input Voltage

The current loop range is 3.8 to 20.5 mA.



### Pulse Output Connections

The pulse output is used for a remote counter. When the preset volume or mass (defined in the totalizer settings, see page 3-10) has passed the meter, the output provides a 50 millisecond square pulse.

The pulse output requires a separate 5 to 36 VDC power supply. The pulse output optical relay is a normally-open single-pole relay. The relay can conduct a current up to 40 mA. It is isolated from the meter electronics and power supply.

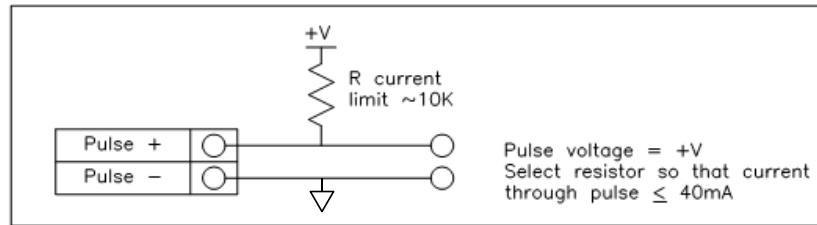

Figure 2-13. Isolated Pulse Output Using External Power Supply

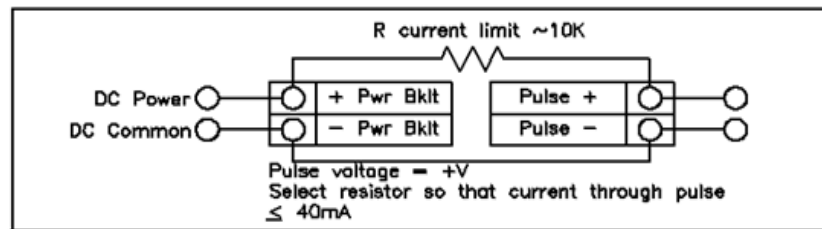

Figure 2-14. Non-Isolated Pulse Output Using External Power Supply

### Frequency Output Connections

The frequency output is used for a remote counter. It can be scaled to output a 1 to 10 kHz signal proportional to mass or volume flow, temperature, pressure or density.

The frequency output requires a separate 5 to 36 VDC power supply. The frequency output optical relay is a normally-open single-pole relay. The output can conduct a current up to 40 mA. It is isolated from the meter electronics and power supply.

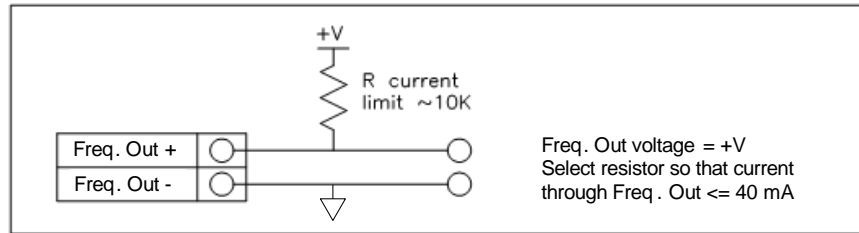

Figure 2-15. Isolated Frequency Output Using External Power Supply

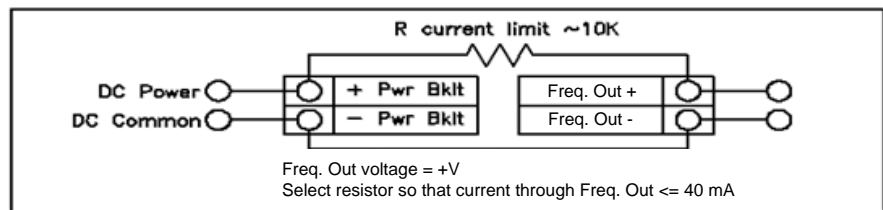

Figure 2-16. Non-Isolated Frequency Output Using External Power Supply

### Optional Backlight Connection

The loop power meter has an optional backlight connection provided. It is intended to be powered by a separate 12 to 36 VDC at 35 mA max. power supply or by the pulse power input. Both options are shown below.

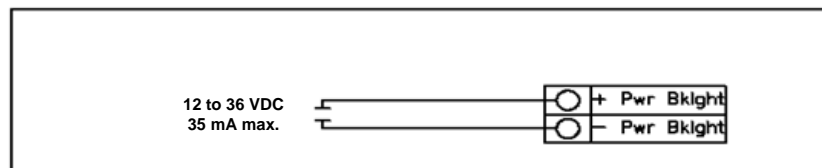

Figure 2-17. Backlight Using External Power Supply

## Remote Electronics Wiring

The remote electronics enclosure should be mounted in a convenient, easy to reach location. For hazardous location installations, make sure to observe agency requirements for installation. Allow some slack in the interface cable between the junction box and the remote electronics enclosure. To prevent damage to the wiring connections, do not put stress on the terminations at any time.

The meter is shipped with temporary strain relief glands at each end of the cable. Disconnect the cable from the meter's terminal block inside the junction box—not at the remote electronics enclosure. Remove both glands and install appropriate conduit entry glands and conduit. The cable entry device shall be of a certified flameproof type, suitable for the conditions of use and correctly installed. The degree of protection of at least IP66 to EN 60529 is only achieved if certified cable entries are used that are suitable for the application and correctly installed. Unused apertures shall be closed with suitable blanking elements. When installation is complete, reconnect each labeled wire to the corresponding terminal position on the junction box terminal block. Make sure to connect each wire pair's shield. Note: incorrect connection will cause the meter to malfunction.

Note: Numeric code in junction box label matches wire labels.

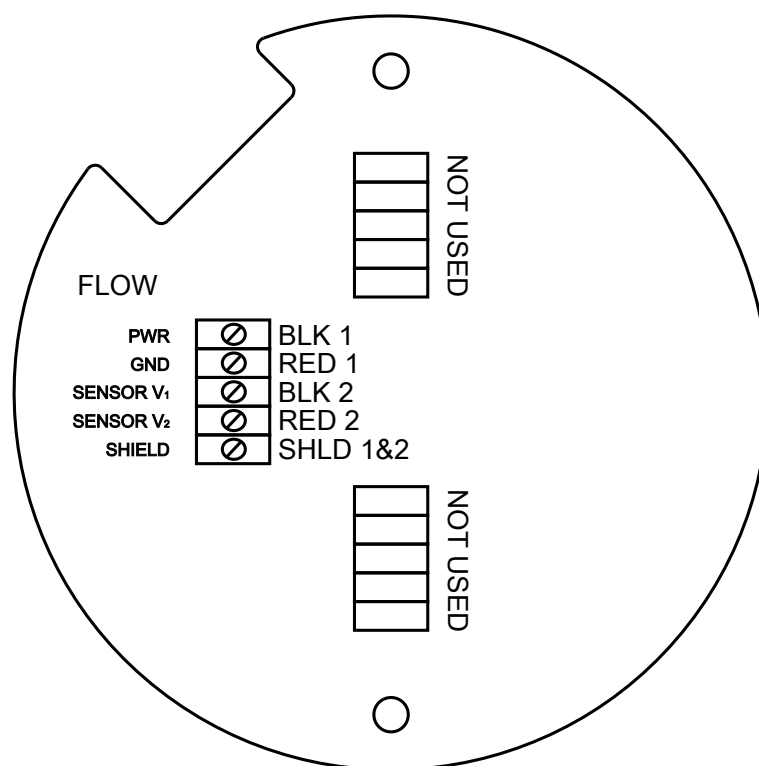

Figure 2-18. Loop Power Volumetric Flowmeter Junction Box Sensor Connections (Wires enter the flow connector from the left side of the connector shown above.)

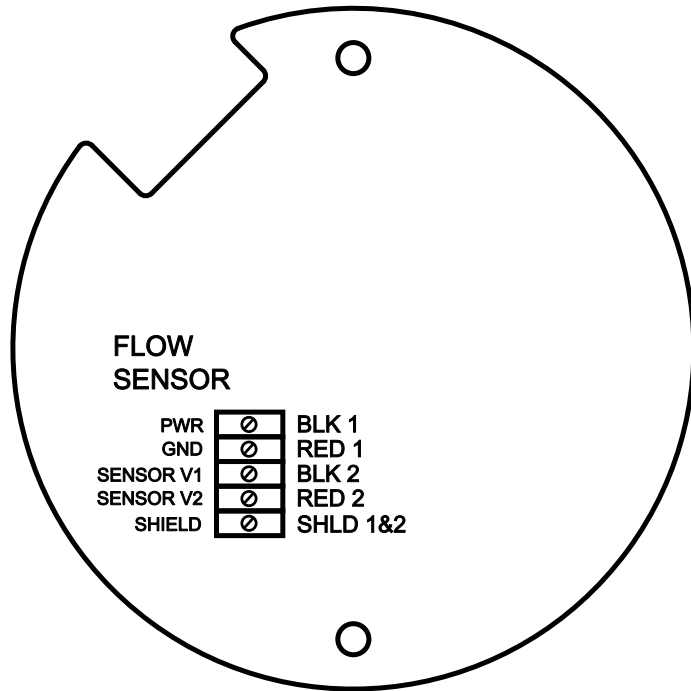

Figure 2-19. Loop Power Volumetric Flowmeter Junction Box Sensor Connections Supplied Prior to Jan. 1, 2014 (Wires enter the flow connector from the right side of the connector shown above.)

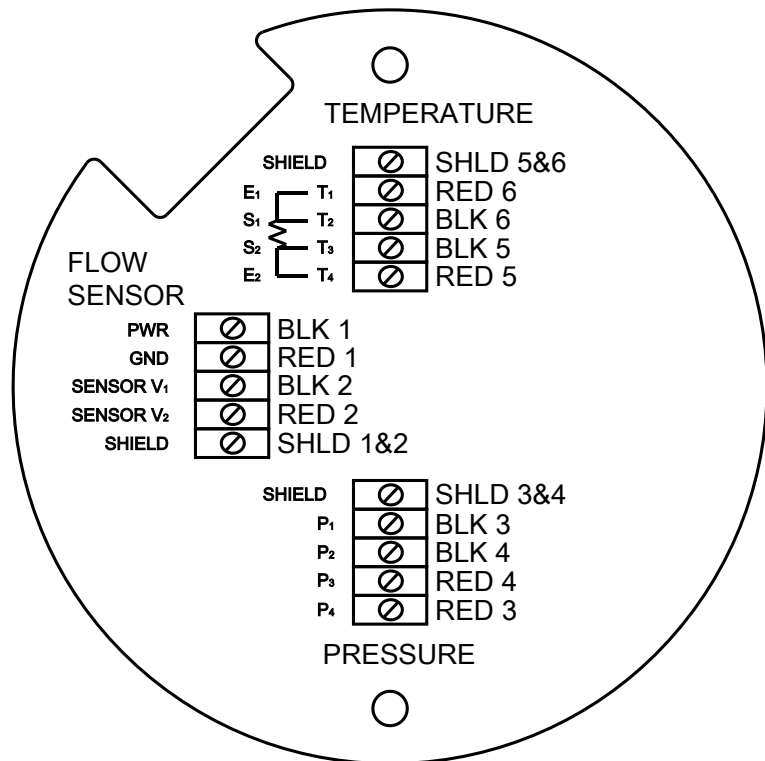

Figure 2-20. Loop Power Mass Flowmeter Junction Box Sensor Connections

## High Power Flow Meter Wiring Connections



### Warning!

To avoid potential electric shock, follow National Electric Code safety practices or your local code when wiring this unit to a power source and to peripheral devices.

Failure to do so could result in injury or death. All AC power connections must be in accordance with published CE directives. All wiring procedures must be performed with the power off.

A power switch is not provided with this meter, an approved switch meeting the power requirements listed in Appendix A must be provided by the user. It must be easily accessible and marked as the disconnect for the flow meter.

Only the connectors supplied with the meter are to be used for connecting wiring.

If the equipment is used in a manner not specified the protection provided by the equipment may be impaired.

The NEMA 4X enclosure contains an integral wiring compartment located in the smaller end of the enclosure. Two 3/4-inch female NPT conduit entries are available for separate power and signal wiring. For all hazardous area installations, only suitable certified cable glands, blanking plugs or thread adapters may be used. The cable entry device shall be of a certified flameproof type, suitable for the conditions of use and correctly installed. The degree of protection of at least IP66 to EN 60529 is only achieved if certified cable entries are used that are suitable for the application and correctly installed. Unused apertures shall be closed with suitable blanking elements. If conduit seals are used, they must be installed within 18 inches (457 mm) of the enclosure.

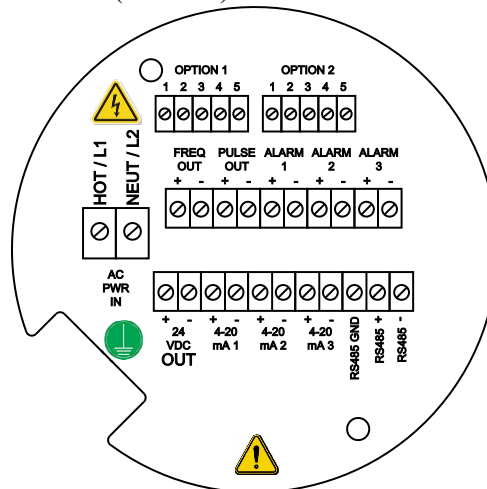

Figure 2-21. AC Wiring Terminals

## Input Power Connections

To access the wiring terminal blocks, locate and loosen the small set screw which locks the small enclosure cover in place. Unscrew the cover to expose the terminal block.

### AC Power Wiring

The AC power wire size must be 20 to 10 AWG with the wire stripped 1/4 inch (7 mm). The wire insulation temperature must meet or exceed 90°C (194°F). Connect 100 to 240 VAC (5 W maximum) to the Hot and Neutral terminals on the terminal block. Connect the ground wire to the safety ground lug. Torque all connections to 4.43 to 5.31 in-lbs (0.5 to 0.6 Nm). Use a separate conduit entry for signal lines to reduce the possibility of AC noise interference.



### Caution!

The AC wire insulation temperature rating must meet or exceed 90°C (194°F), maximum operating voltage 600 VRMS.

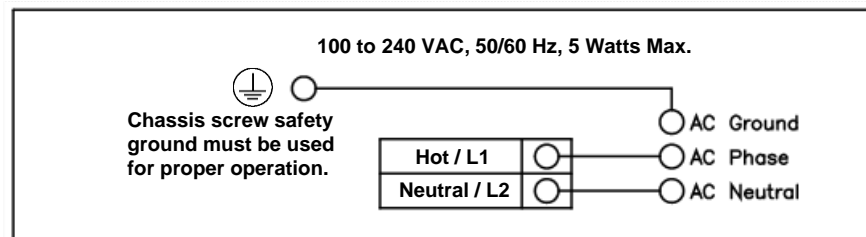

Figure 2-22. AC Power Connections

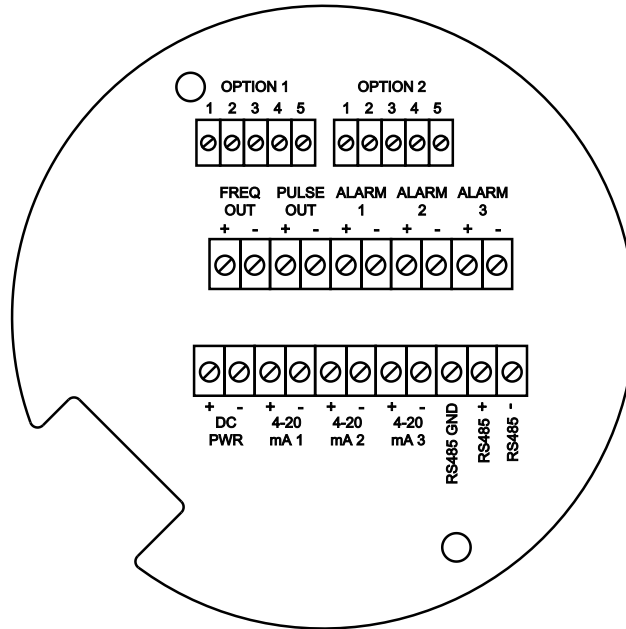

Figure 2-23. DC Wiring Terminals

### DC Power Wiring

The DC power wire size must be 20 to 12 AWG with the wire stripped 1/4 inch (7 mm). Connect 18 to 36 VDC (300 mA, 9 W maximum) to the +DC Pwr and –DC Pwr terminals on the terminal block. Torque all connections to 4.43 to 5.31 in-lbs (0.5 to 0.6 Nm).



**Warning!**

Use a Class 2 isolated power supply that is grounded, provides DC output, and has no more than 10% output ripple.

A power switch is not provided with this meter, an approved switch meeting the power requirements listed in Appendix A must be provided by the user. It must be easily accessible and marked as the disconnect for the flow meter.

Only the connectors supplied with the meter are to be used for connecting wiring.

If the equipment is used in a manner not specified the protection provided by the equipment may be impaired.



**Caution!**

The DC wire insulation temperature rating must meet or exceed 85°C (185°F), maximum operating voltage 300 VRMS.

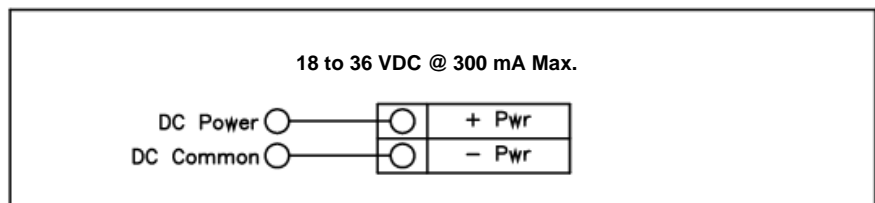

Figure 2-24. DC Power Connections

## 4-20 mA Output Connections

The standard Pro-T™ Flow Meter has a single 4-20 mA loop. Two additional loops are available on the optional communication board. The 4-20 mA loop current is controlled by the meter electronics. The electronics must be wired in series with the sense resistor or current meter. The current control electronics require 12 volts at the input terminals to operate correctly.

The maximum loop resistance (load) for the current loop output is dependent upon the supply voltage and is given in Figure 2-25. The 4-20 mA loop is optically isolated from the flow meter electronics.

$R_{load}$  is the total resistance in the loop, including the wiring resistance ( $R_{load} = R_{wire} + R_{sense}$ ). To calculate  $R_{max}$ , the maximum  $R_{load}$  for the loop, subtract the minimum terminal voltage from the supply voltage and divide by the maximum loop current, 20 mA. Thus:

$$\text{The maximum resistance } R_{load} = R_{max} = (V_{supply} - 12V) / 0.020 \text{ A}$$

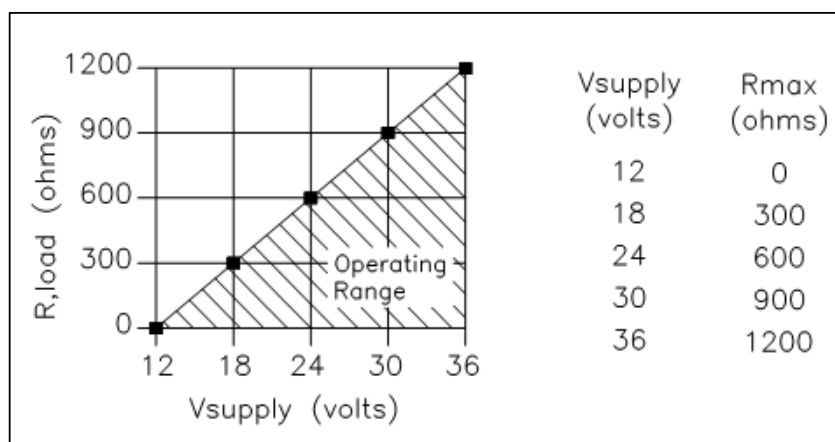

Figure 2-25. Load Resistance Versus Input Voltage

The current loop range is 3.8 to 20.5 mA.

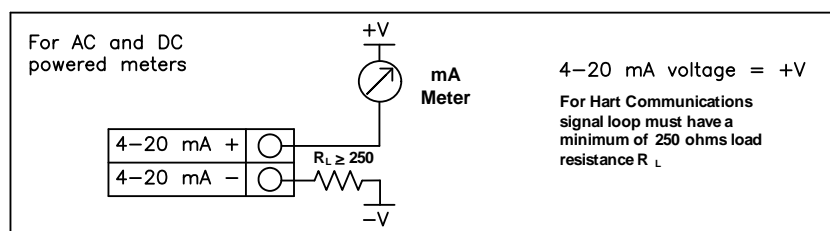

Figure 2-26. Isolated 4-20 mA Output Using External Power Supply

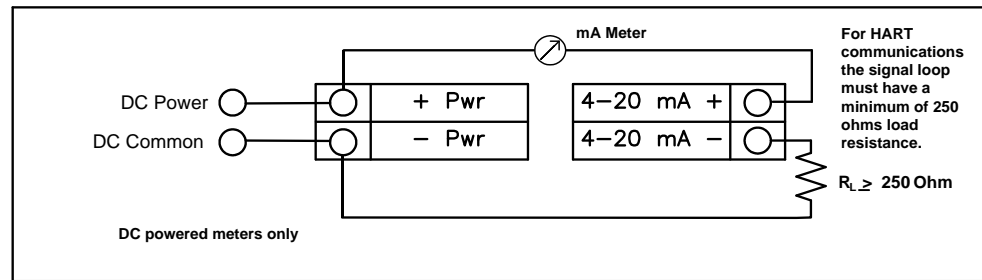

Figure 2-27. Non-Isolated 4–20 mA Output Using Meter Input Power Supply

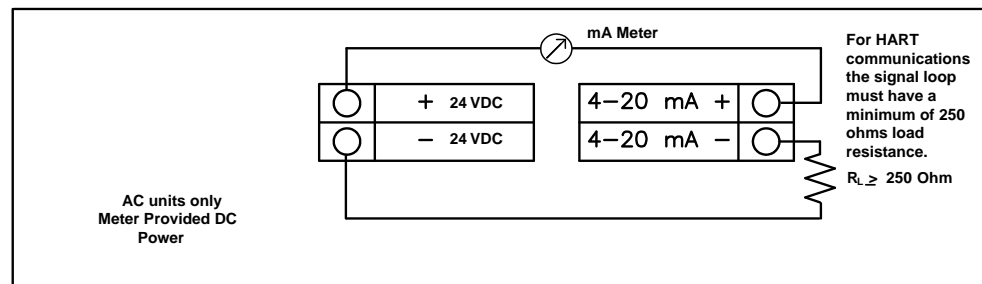

Figure 2-28. Isolated 4–20 mA Output Using Meter Provided Power Supply

## Frequency Output Connections

The frequency output is used for a remote counter. It can be scaled to output a 1 to 10 kHz signal proportional to mass or volume flow, temperature, pressure or density.

The frequency output requires a separate 5 to 36 VDC power supply. The frequency output optical relay is a normally-open single-pole relay. The output can conduct a current up to 40 mA. It is isolated from the meter electronics and power supply.

There are three connection options for the frequency output—the first with a separate power supply (Figure 2-29), the second using the flow meter power supply (Figure 2-30)(DC powered units only), and the third using the internal 24 VDC power supply (Figure 2-31)(AC powered units only). Use the first option with a separate power supply (5 to 36 VDC) if a specific voltage is needed for the frequency output. Use the second configuration if the voltage at the flow meter power supply is an acceptable driver voltage for the load connected. (Take into account that the current used by the frequency load comes from the meter's power supply). Use the third configuration if you have an AC powered unit only. In any case, the voltage of the frequency output is the same as the voltage supplied to the circuit.



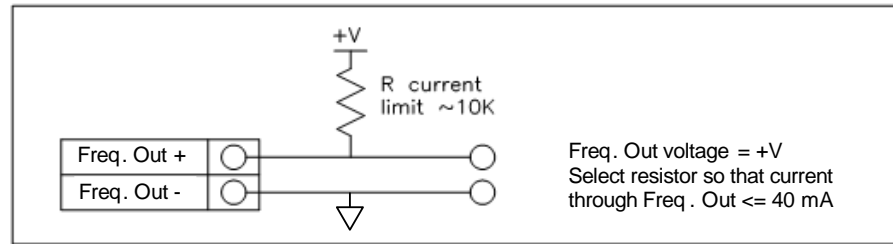

Figure 2-29. Isolated Frequency Output Using External Power Supply

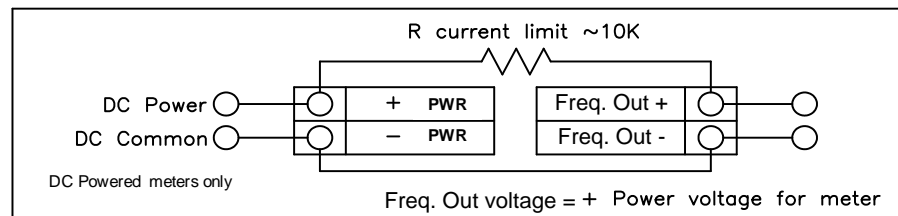

Figure 2-30. Non-Isolated Frequency Output Using Input Power Supply

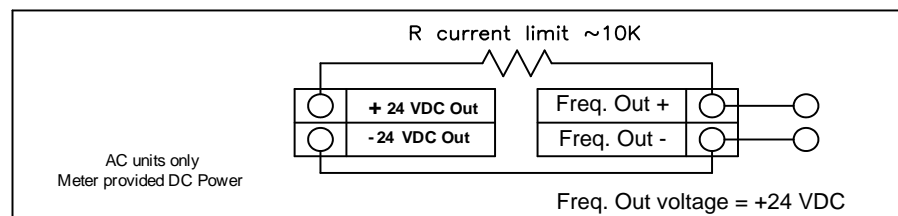

Figure 2-31. Isolated Frequency Output Using Meter Provided Power Supply

## Pulse Output Connections

The pulse output is used for a remote counter. When the preset volume or mass (defined in the totalizer settings, see page 3-10) has passed the meter, the output provides a 50 millisecond square pulse.

The pulse output requires a separate 5 to 36 VDC power supply. The pulse output optical relay is a normally-open single-pole relay. The relay can conduct a current up to 40 mA. It is isolated from the meter electronics and power supply.

There are three connection options for the pulse output—the first with a separate power supply (Figure 2-32), the second using the flow meter power supply (Figure 2-33)(DC powered units only), and the third using the internal 24 VDC power supply (Figure 2-34)(AC powered units only). Use the first option with a separate power supply (5 to 36 VDC) if a specific voltage is needed for the pulse output. Use the second configuration if the voltage at the flow meter power supply is an acceptable driver voltage for the load connected. (Take into account that the current used by the pulse load comes from the meter's power supply). Use the third configuration if you have an

AC powered unit only. In any case, the voltage of the pulse output is the same as the voltage supplied to the circuit.

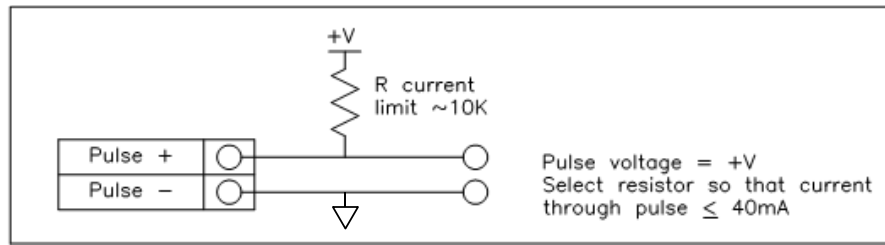

Figure 2-32. Isolated Pulse Output Using External Power Supply

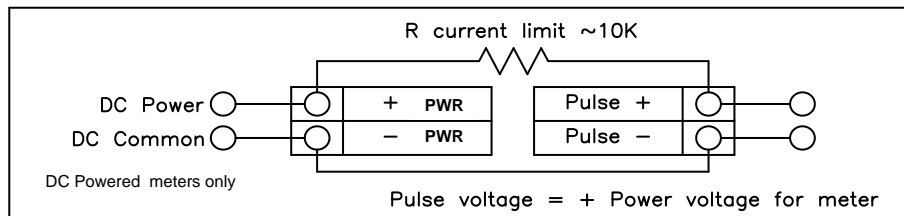

Figure 2-33. Non-Isolated Pulse Output Using Input Power Supply

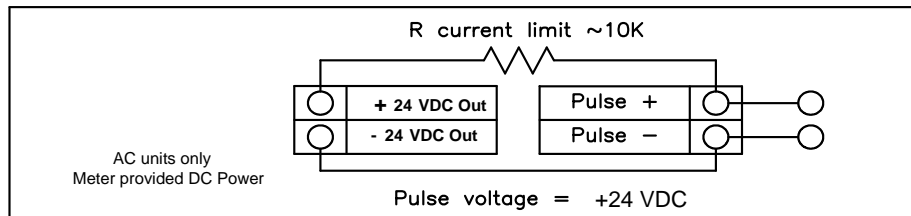

Figure 2-34. Isolated Pulse Output Using Meter Provided Power Supply

## Alarm Output Connections

One alarm output (Alarm 1) is included on the standard Pro-V™ Flow Meter. Two or more alarms (Alarm 2 and Alarm 3) are included on the optional communication board. The alarm output requires a separate 5 to 36 VDC power supply. The alarm output optical relay is a normally-open single-pole relay. The relay can conduct a current up to 40 mA. It is isolated from the meter electronics and power supply. When the alarm relay is closed, the current draw will be constant. Make sure to size  $R_{load}$  appropriately.

There are three connection options for the alarm output—the first with a separate power supply (Figure 2-35), the second using the flow meter power supply (Figure 2-36)(DC powered units only) and the third with the meter provided power supply (Figure 2-37)(AC powered units only). Use the first option with a separate power supply (5 to 36 VDC) if a specific voltage is needed for the alarm output. Use the second configuration if the voltage at the flow meter power supply is an acceptable driver voltage for the load connected. (Take into account that the current used by the alarm load comes from the meter's power supply). Use the third if you have an AC powered unit only. In any case, the voltage of the alarm output is the same as the voltage supplied to the circuit.

The alarm output is used for transmitting high or low process conditions as defined in the alarm settings (see page 3-9).

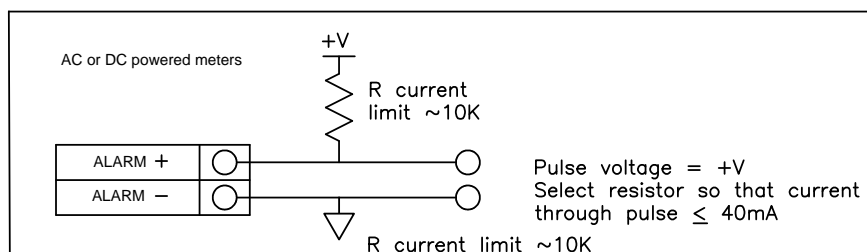

Figure 2-35. Isolated Alarm Output Using External Power Supply

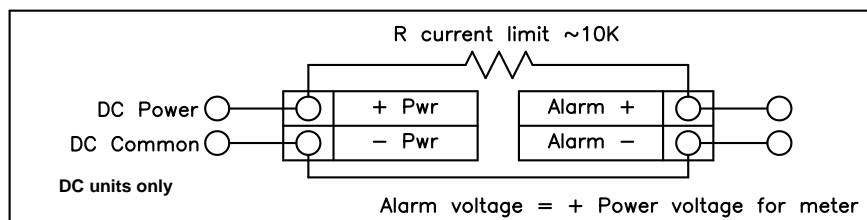

Figure 2-36. Non-Isolated Alarm Output Using Internal Power Supply

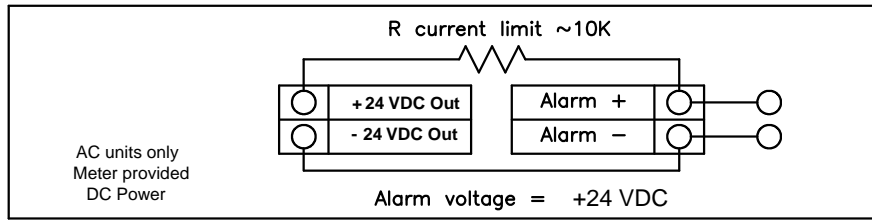

Figure 2-37. Isolated Alarm Output Using Meter Provided Power Supply

### Remote Electronics Wiring

The remote electronics enclosure should be mounted in a convenient, easy to reach location. For hazardous location installations, make sure to observe agency requirements for installation. Allow some slack in the interface cable between the junction box and the remote electronics enclosure. To prevent damage to the wiring connections, do not put stress on the terminations at any time.

The meter is shipped with temporary strain relief glands at each end of the cable. Disconnect the cable from the meter’s terminal block inside the junction box—not at the remote electronics enclosure. Remove both glands and install appropriate conduit entry glands and conduit. The cable entry device shall be of a certified flameproof type, suitable for the conditions of use and correctly installed. The degree of protection of at least IP66 to EN 60529 is only achieved if certified cable entries are used that are suitable for the application and correctly installed. Unused apertures shall be closed with suitable blanking elements. When installation is complete, reconnect each labeled wire to the corresponding terminal position on the junction box terminal block. Make sure to connect each wire pair’s shield. Note: incorrect connection will cause the meter to malfunction.

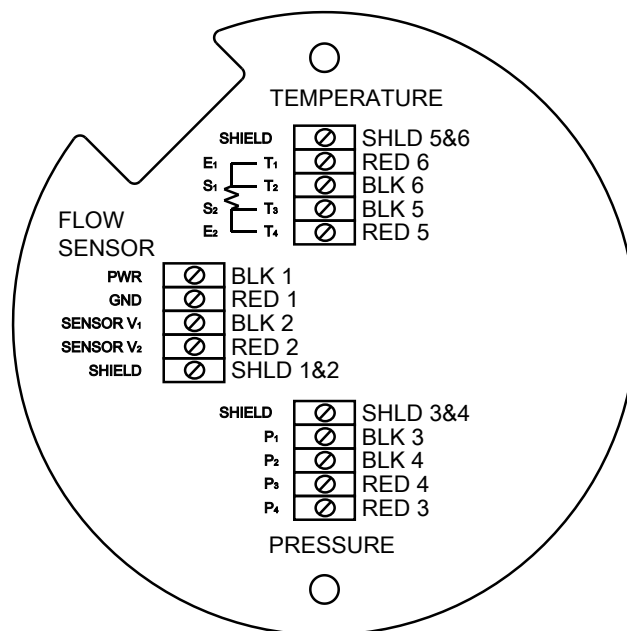
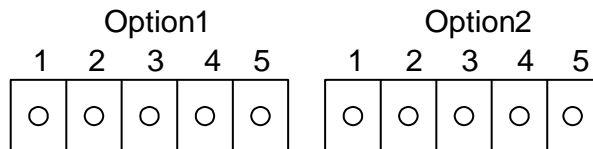

Figure 2-38. High Power Flow Meter Junction Box Sensor Connections

Note: Numeric code in junction box label matches wire labels.

### Optional Input Electronics Wiring

The meter has two optional input wiring terminals, maximum wire size is 16 AWG. These can be used to input a Remote or Second RTD input in the case of an Energy Monitoring meter, for the input of a Remote Pressure Transducer, to pass a Contact Closure or for a Remote Density measurement to name a few. In any case, the wiring diagram will be included with the meter if any of the options are specified. Otherwise, the optional terminal blocks will be left blank and non-functional.



### Optional Energy EMS RTD Input Wiring

#### Loop Power

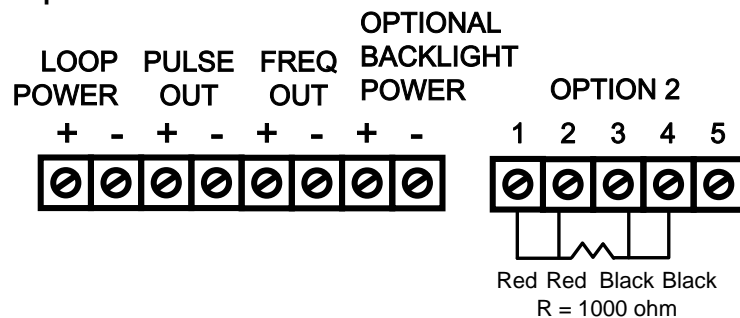

\* Other input options available.

#### High Power

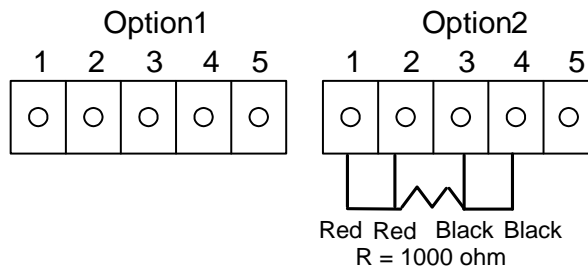

Figure 2-39. Optional Energy EMS RTD Input Wiring

The recommended customer supplied second RTD is a Class A 1000 ohm 4-wire platinum RTD. If a second RTD is not being used, then the factory supplied 1000 ohm resistor needs to be installed in its place.

### Optional External 4-20 mA Input Wiring

The meter is set to have Option 1 used for the external input. Programming menus that pertain to the optional 4-20 mA input are located in the Hidden Diagnostics Menu in Chapter 5.

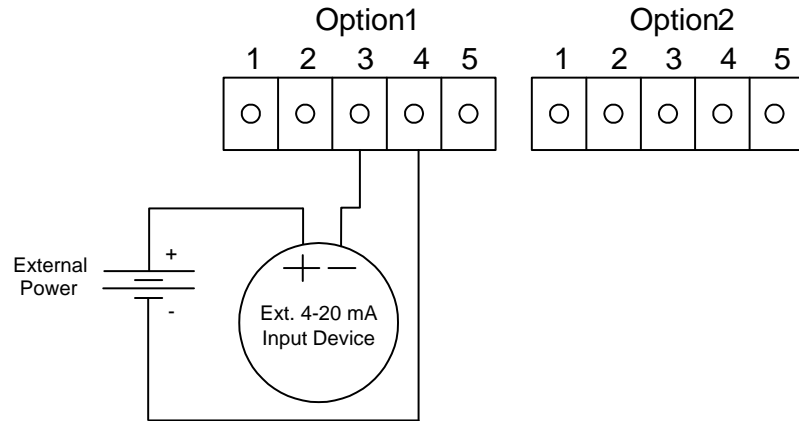

Figure 2-40. External 4-20 mA Input Wiring - External Power Supply

Follow the above diagram to wire the external 4-20 mA input into the flow meter using an external power supply.

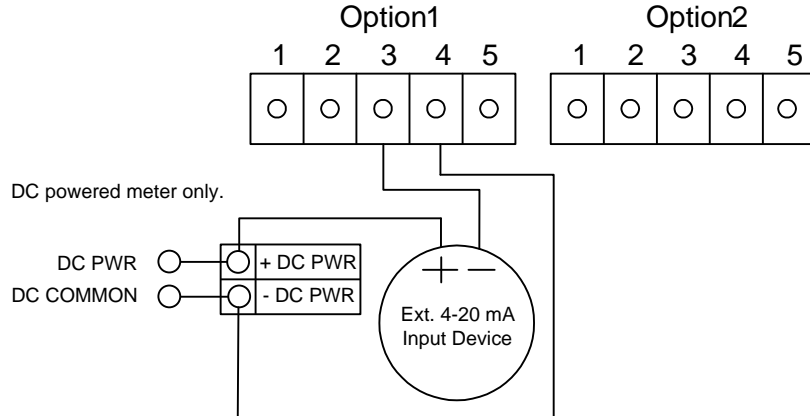

Figure 2-41. External 4-20 mA Input Wiring - DC Powered Meter

Follow the above diagram to wire the external 4-20 mA input into the flow meter using power supplied to the input of a DC powered meter.

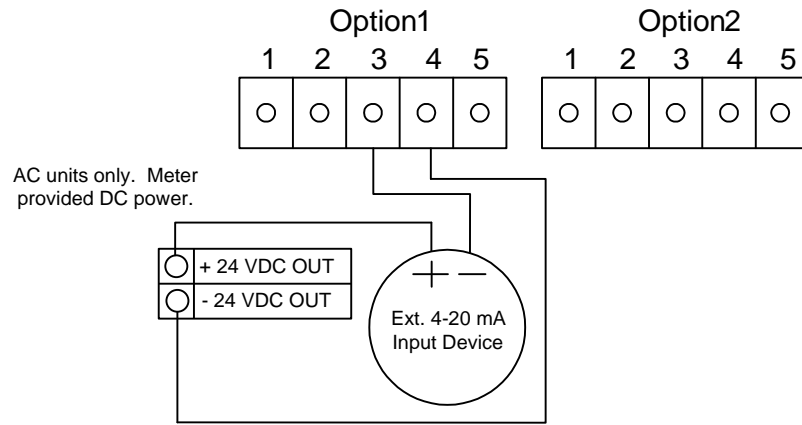

Figure 2-42. External 4-20 mA Input Wiring - AC Powered Meter

Follow the above diagram to wire the external 4-20 mA input into the flow meter using power from the 24 VDC output of an AC powered meter.

### Optional External 4-20 mA Input and RTD Wiring

#### Loop Power

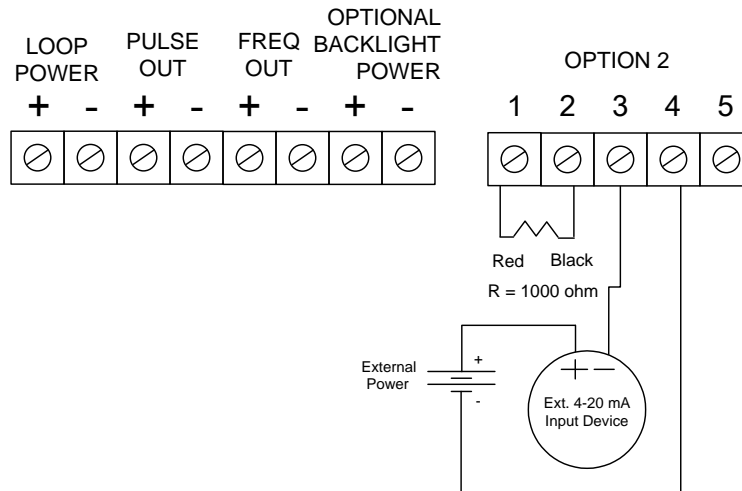

Figure 2-43. External 4-20 mA Input and RTD Wiring – Loop Power

**High Power**

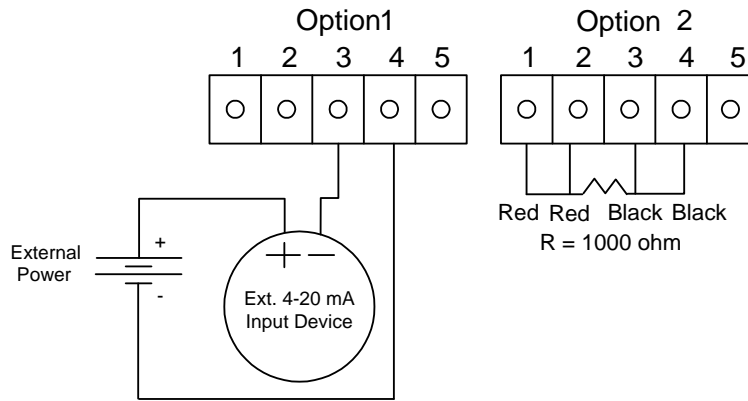

Figure 2-44. External 4-20 mA Input and RTD Wiring – High Power

**Optional Energy EMS External 4-20 mA Input and RTD Wiring**

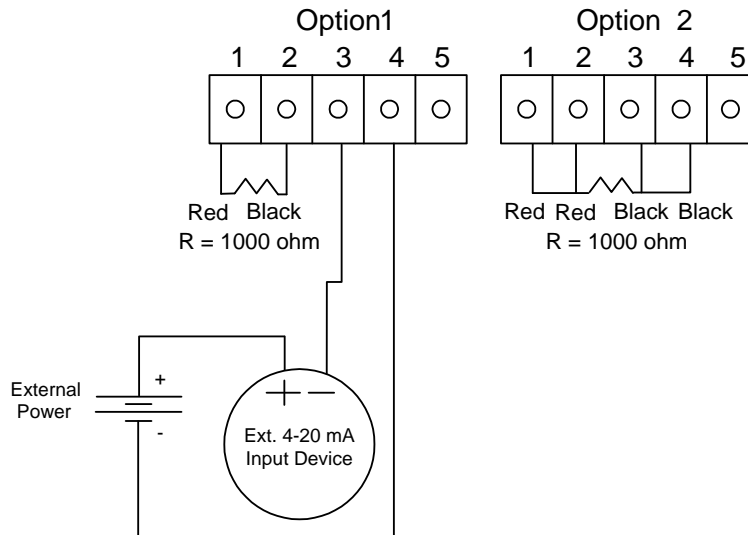

Figure 2-45. Energy EMS External 4-20 mA Input and RTD Wiring – High Power



### Optional External Contact Closure Input Wiring

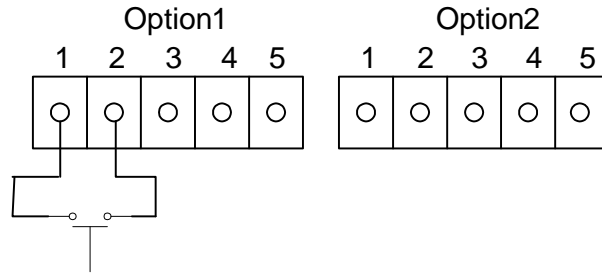

Figure 2-46. Optional External Contact Closure Input Wiring

Follow the above diagram to wire an external switch input into the flow meter. The meter is configured to have Option 1 used for the external input. If the above switch is used to remotely reset the totalizer a pushbutton switch with a momentary contact closure is recommended.

## Chapter 3 Operating Instructions

After installing the Pro-T™ Insertion Turbine Flow Meter, you are ready to begin operation. The sections in this chapter explain the display/keypad commands, meter start-up and programming. The meter is ready to operate at start up without any special programming. To enter parameters and system settings unique to your operation, see the following pages for instructions on using the setup menus.



### Warning!

Do not open covers when an explosive atmosphere may be present.

## Flow Meter Display/Keypad

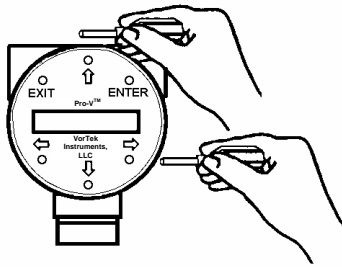

The flow meter's digital electronics allow you to set, adjust and monitor system parameters and performance. A full range of commands are available through the display/keypad. The LCD display gives 2 x 16 characters for flow monitoring and programming. The six push-buttons can be operated with the enclosure cover removed. Or, the explosion-proof cover can remain in place and the keypad operated with a hand-held magnet positioned at the side of the enclosure as shown in the illustration at the left. To secure the enclosure cover use a 1/16" hex key wrench to tighten the 6-32 x 1/4 cup point socket set locking screw.

Display/Keypad Commands	From the Run Mode, the <b>ENTER</b> key allows access to the Setup Menus (through a password screen). Within the Setup Menus, pressing <b>ENTER</b> activates the current field. To set new parameters, press the <b>ENTER</b> key until an underline cursor appears. Use the $\uparrow\downarrow\leftarrow\rightarrow$ keys to select new parameters. Press <b>ENTER</b> to continue. (If change is not allowed, <b>ENTER</b> has no effect.) All outputs are disabled when using the Setup Menus.
	<p>The <b>EXIT</b> key is active within the Setup Menus. When using a Setup Menu, <b>EXIT</b> returns you to the Run Mode. If you are changing a parameter and make a mistake, <b>EXIT</b> allows you to start over.</p>
	<p>The <math>\uparrow\downarrow\leftarrow\rightarrow</math> keys advance through each screen of the current menu. When changing a system parameter, all <math>\uparrow\downarrow\leftarrow\rightarrow</math> keys are available to enter new parameters.</p>

Figure 3-1. Flow Meter Display/Keypad

## Display Contrast Adjustment

The flow meter display contrast is set at the factory but if the display characters appear too dark or too light proceed as follows:

- 1) Hold down the “Exit” button on the front panel for 5 to 10 seconds. “Setting Contrast” will appear.
- 2) Push the “Up” arrow to darken the display or the “Down” arrow to lighten it.
- 3) Push the “Enter” button to save the contrast setting.

## Start-Up

To begin flow meter operation:

1. Verify the flow meter is installed and wired as described in Chapter 2.
2. Apply power to the meter. At start up, the unit runs a series of self-tests that check the RAM, ROM, EPROM and all flow sensing components. After completing the self-test sequence, the Run Mode screens appear.
3. The Run Mode displays flow information as determined by system settings. Some screens depicted on the next page may not be displayed based on these settings. Press the  $\uparrow$  $\downarrow$  arrow keys to view the Run Mode screens.
4. Press the ENTER key from any Run Mode screen to access the Setup Menus. Use the Setup Menus to configure the meter’s multi-parameter features to fit your application.



### Note

Starting the flow meter or pressing EXIT will always display the Run Mode screens.

# Run Mode Screens

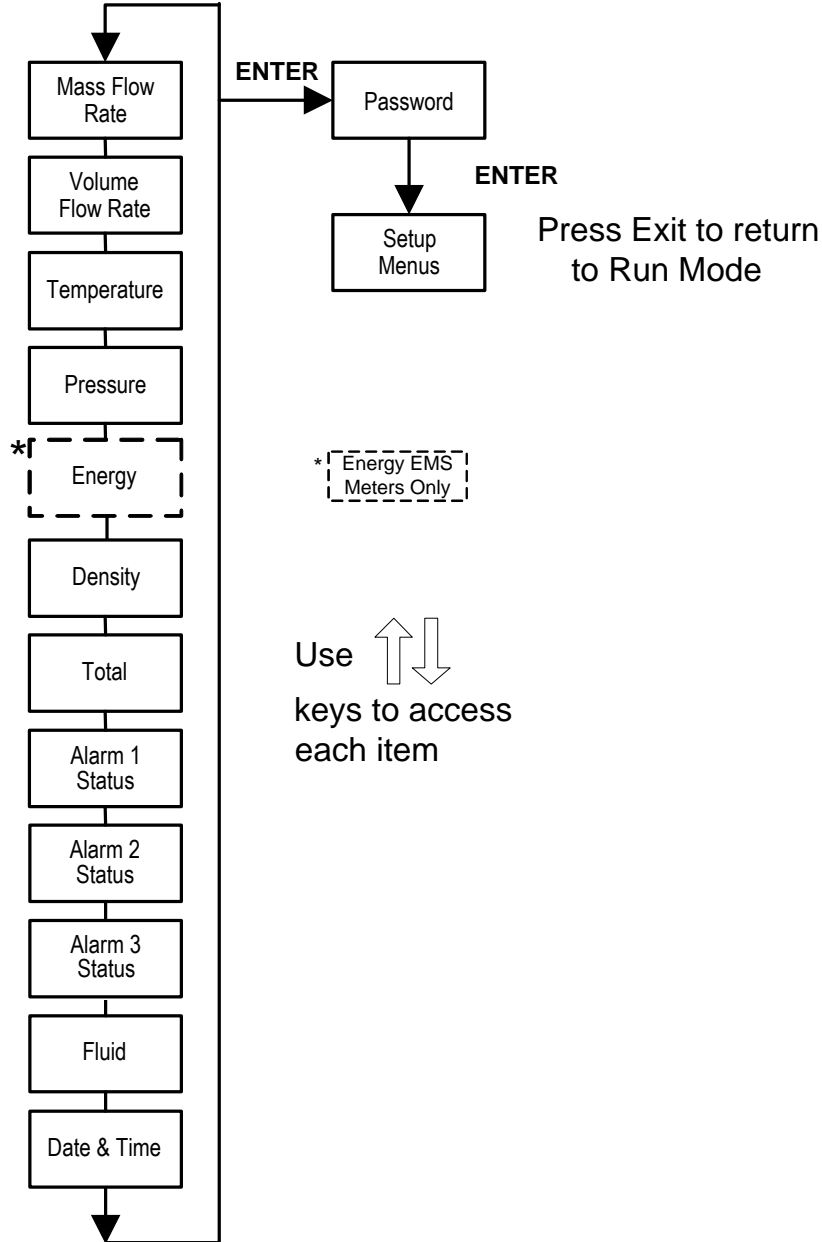

# Using the Setup Menus

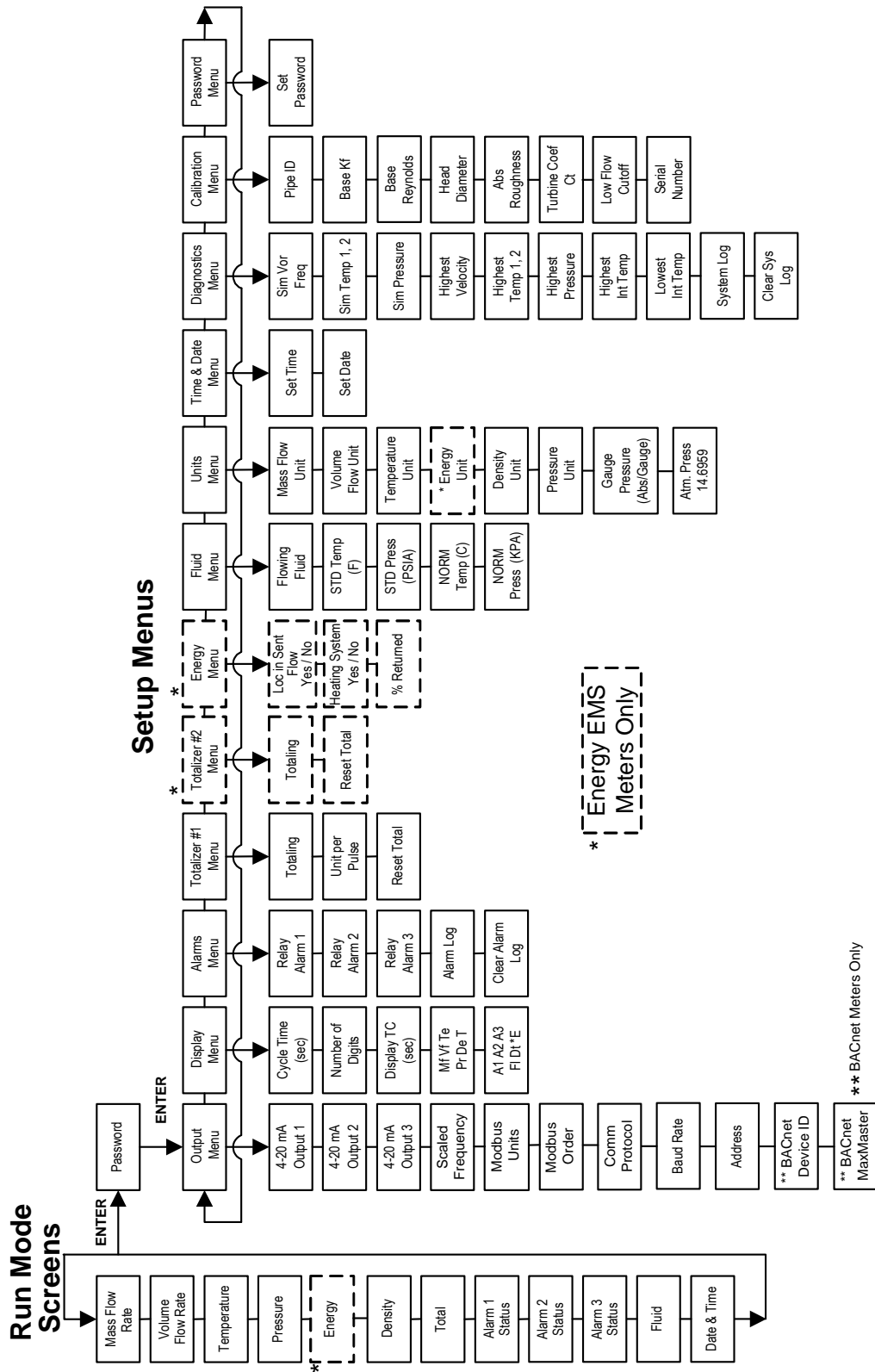

---

## ***Programming the Flow Meter***

1. Enter the Setup Menu by pressing the ENTER key until prompted for a password. (All outputs are disabled while using the Setup Menus.)
2. Use the ↑↓⇐⇒ keys to select the password characters (1234 is the factory-set password). When the password is correctly displayed, press ENTER to continue.
3. Use the Setup Menus described on the following pages to customize the multi-parameter features of your Pro-T™ Flow Meter. (The entire lower display line is available for entering parameters.) Some items depicted in the graphic on the preceding page may not be displayed based on flow meter configuration settings
4. To activate a parameter, press ENTER. Use the ↑↓⇐⇒ keys to make selections. Press ENTER to continue. Press EXIT to save or discard changes and return to Run Mode.
5. **Program the UNITS menu first because later menus will be based on the units selected.**

# Output Menu

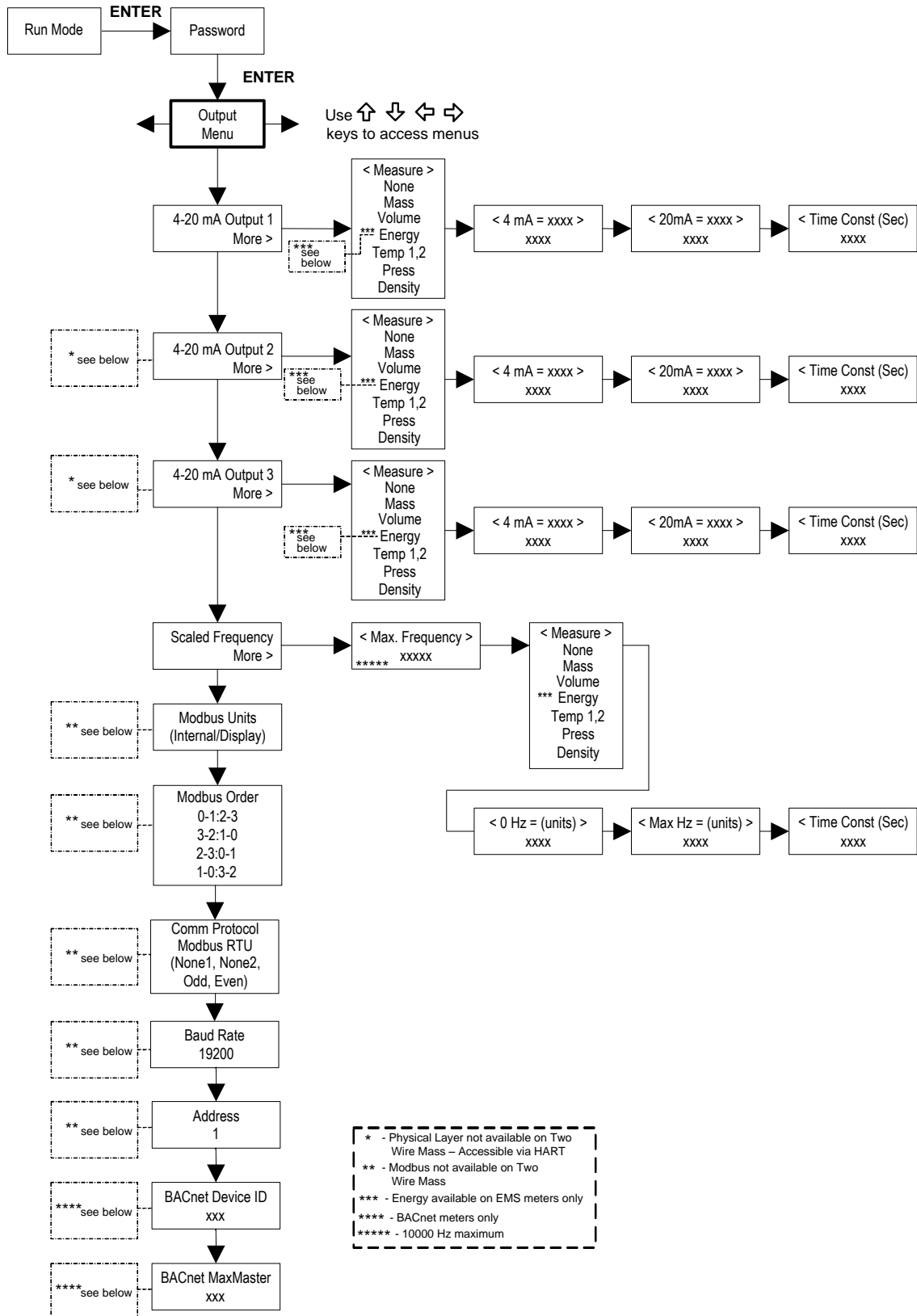

## Example for Setting an Output

The following shows how to set Output 1 to measure mass flow with 4 mA = 0 lb/hr and 20 mA = 100 lb/hr with a time constant of 5 seconds. (All outputs are disabled while using the Setup Menus.)

First, set the desired units of measurement:

1. Use  $\leftarrow\rightarrow$  keys to move to the Units Menu (see page 3-12).
2. Press  $\downarrow$  key until Mass Flow Unit appears. Press ENTER.
3. Press  $\downarrow$  key until lb appears in the numerator. Press  $\rightarrow$  key to move the underline cursor to the denominator. Press the  $\downarrow$  key until hr appears in the denominator. Press ENTER to select.
4. Press  $\uparrow$  key until Units Menu appears.

Second, set the analog output:

1. Use  $\leftarrow\rightarrow$  keys to move to the Output Menu.
2. Press the  $\downarrow$  key until 4-20 mA Output 1 appears.
3. Press  $\rightarrow$  key to access Measure selections. Press ENTER and press the  $\downarrow$  key to select Mass. Press ENTER.
4. Press  $\rightarrow$  key to set the 4 mA point in the units you have selected for mass of lb/hr. Press ENTER and use  $\uparrow\downarrow\leftarrow\rightarrow$  keys to set 0 or 0.0. Press ENTER.
5. Press  $\rightarrow$  key to set the 20 mA point. Press ENTER and use  $\uparrow\downarrow\leftarrow\rightarrow$  keys to set 100 or 100.0. Press ENTER.
6. Press  $\rightarrow$  key to select the Time Constant. Press ENTER and use  $\uparrow\downarrow\leftarrow\rightarrow$  keys to select 5. Press ENTER.
7. Press the EXIT key and answer YES to permanently save your changes.

## Example for Calculating Output Current

Assume Output 1 is scaled as above for mass flow with 4 mA = 0 lb/hr and 20 mA = 100 lb/hr.

Output 1 current = ((Flow rate / 100) x 16 mA) + 4 mA



## Display Menu

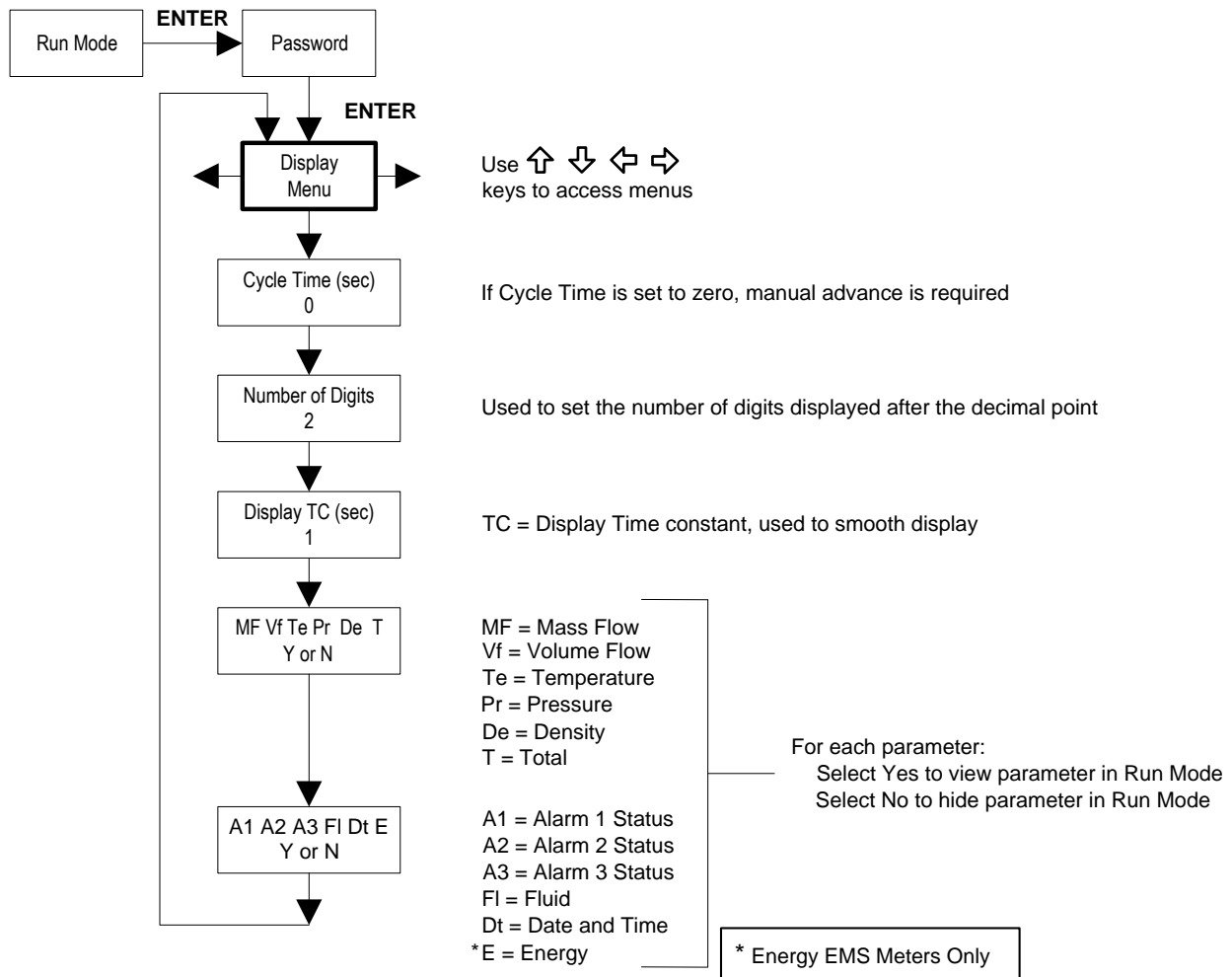

Use the Display Menu to set the cycle time for automatic screen sequencing used in the Run Mode, change the precision of displayed values, smooth the values or enable or disable each item displayed in the Run Mode screens.

### Example for Changing a Run Mode Display Item

The following shows how to remove the temperature screen from the Run Mode screens. Note: all outputs are disabled while using the Setup Menus.

1. Use ← → keys to move to the Display Menu.
2. Press ↓ key until Mf Vf Pr Te De T appears.
3. Press ENTER to select. Press → key until the cursor is positioned below Te.
4. Press ↓ key until N appears. Press ENTER to select.
5. Press EXIT and then ENTER to save changes and return to the Run Mode.

## Alarms Menu

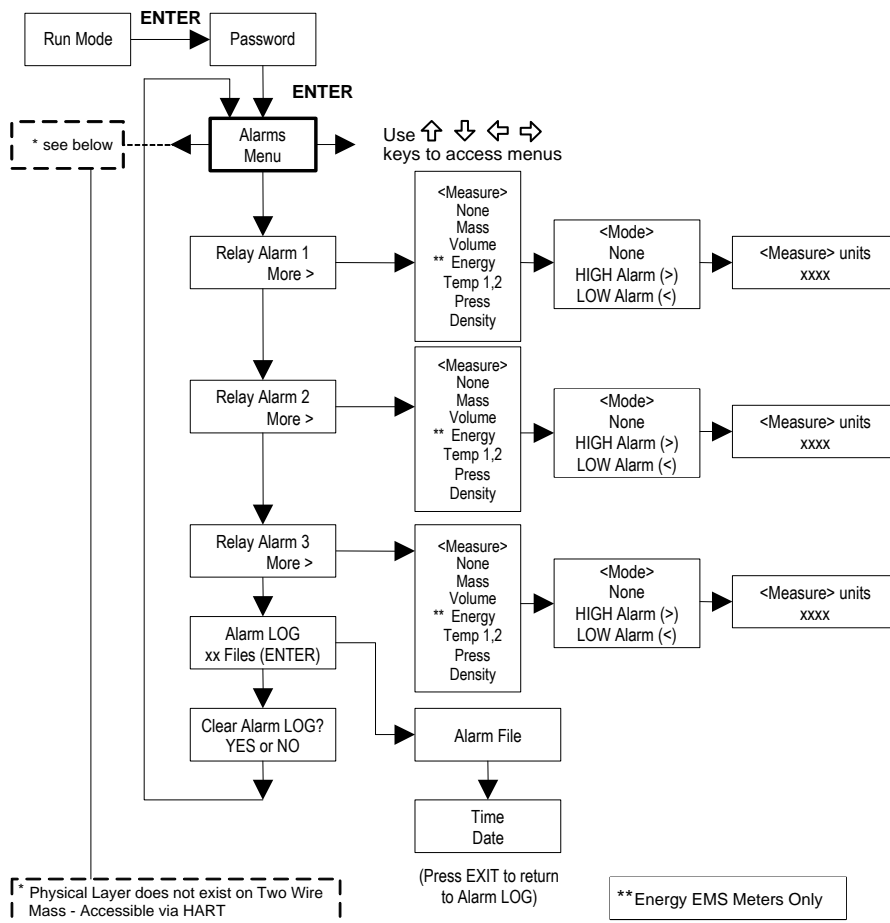

### Example for Setting an Alarm

The following shows how to set Relay Alarm 1 to activate if the mass flow rate is greater than 100 lb/hr. You can check the alarm configuration in the Run Mode by pressing the  $\uparrow$  $\downarrow$  keys until Alarm [1] appears. The lower line displays the mass flow rate at which the alarm activates. Note: all outputs are disabled while using the Setup Menus.

First, set the desired units of measurement:

1. Use  $\leftarrow$  $\rightarrow$  keys to move to the Units Menu (see to page 3-12).
2. Press  $\downarrow$  key until Mass Flow Unit appears. Press ENTER.
3. Press  $\downarrow$  key until lb appears in the numerator. Press  $\rightarrow$  key to move the underline cursor to the denominator. Press the  $\downarrow$  key until hr appears in the denominator. Press ENTER to select.
4. Press  $\uparrow$  key until Units Menu appears.

Second, set the alarm:

1. Use  $\leftarrow$  $\rightarrow$  keys to move to the Alarms Menu.
2. Press the  $\downarrow$  key until Relay Alarm 1 appears.
3. Press  $\rightarrow$  key to access Measure selections. Press ENTER and use the  $\downarrow$  key to select Mass. Press ENTER.
4. Press  $\rightarrow$  key to select the alarm Mode. Press ENTER and use  $\downarrow$  key to select HIGH Alarm. Press ENTER.
5. Press  $\rightarrow$  key to select the value that must be exceeded before the alarm activates. Press ENTER and use  $\uparrow$  $\downarrow$  $\leftarrow$  $\rightarrow$  keys to set 100 or 100.0. Press ENTER.
6. Press the EXIT key to save your changes. (Alarm changes are always permanently saved.)  
(Up to three relay alarm outputs are available depending on meter configuration.)

## Totalizer #1 Menu

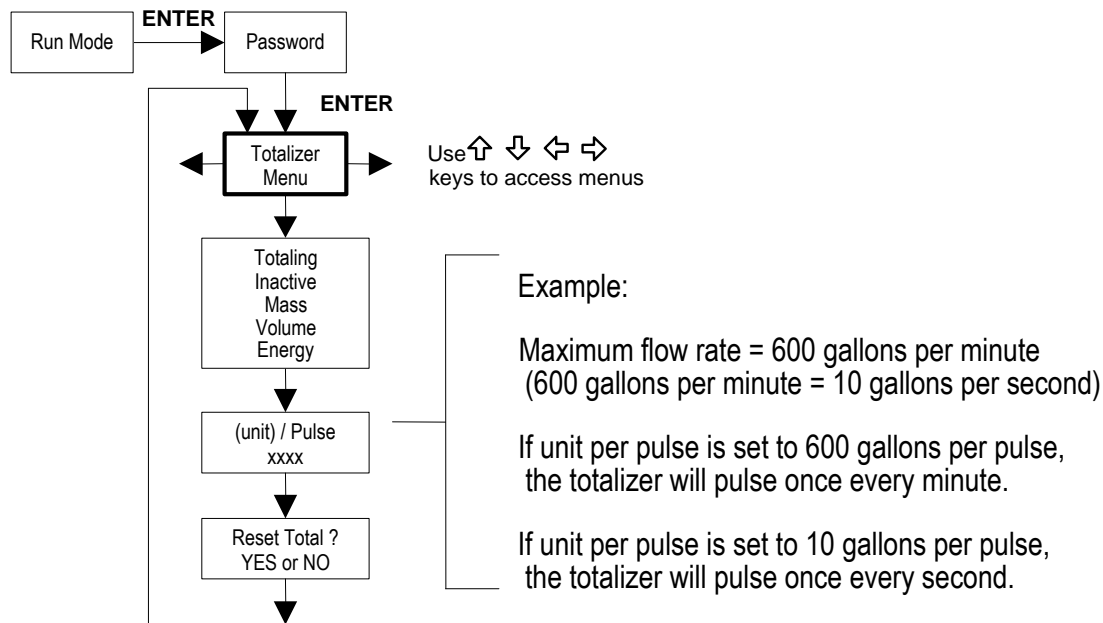

Use the Totalizer Menu to configure and monitor the totalizer. The totalizer maximum count is 999,999,999 at which point it will roll over to 0. The totalizer output is a 50 millisecond (.05 second) positive pulse (relay closed for 50 milliseconds). The totalizer cannot operate faster than one pulse every 100 millisecond (.1 second). A good rule to follow is to set the unit per pulse value equal to the maximum flow in the same units per second. This will limit the pulse to no faster than one pulse every second.

### Example for Setting the Totalizer

The following shows how to set the totalizer to track mass flow in kg/sec. (All outputs are disabled while using the Setup Menus.)

First, set the desired units of measurement:

1. Use ←⇒ keys to move to the Units Menu (see to page 3-12).
2. Press ↓ key until Mass Flow Unit appears. Press ENTER.
3. Press ↓ key until kg appears in the numerator. Press ⇒ key to move the underline cursor to the denominator. Press the ↓ key until sec appears in the denominator. Press ENTER to select.
4. Press ↑ key until Units Menu appears.

Second, set the pulse output:

1. Use ←⇒ keys to move to the Totalizer Menu.
2. Press the ↓ key until Totaling appears.
3. Press ENTER and press the ↓ key to select Mass. Press ENTER.
4. Press ↓ key to set the pulse output in the units you have selected for mass flow of kg/sec. Press ENTER and use ↑↓←⇒ keys to set the pulse value equal to the maximum flow in the same units per second. Press ENTER.
5. To reset the totalizer, press ↓ key until Reset Total? appears. Press ENTER and the ↓ key to reset the totalizer if desired. Press ENTER.
6. Press the EXIT key and answer YES to permanently save your changes.

## Totalizer #2 Menu

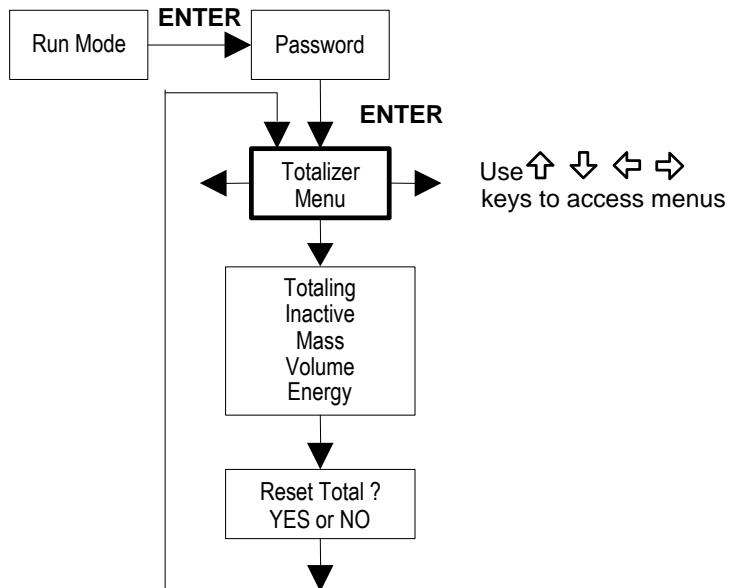

Use the Totalizer #2 to Monitor Flow or Energy. The totalizer maximum count is 999,999,999 at which point it will roll over to 0. Note that Totalizer #2 does not operate a relay, it is for monitoring only.

## Energy Menu – For EMS Energy Meters Only

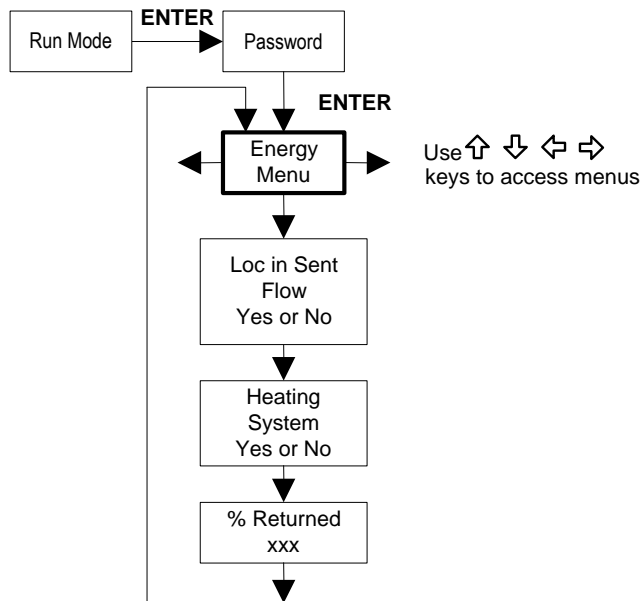

### Configuration:

There are several possibilities regarding the measurement of water or steam energy given the location of the meter and the use of a second RTD. The table below summarizes the possibilities:

Fluid	Meter Location	Second RTD	Measurement
Water	“Sent” Flow Line	“Return Flow Line	Change in Energy
Water	“Return” Flow Line	“Sent” Flow Line	Change in Energy
Water	“Sent” Flow Line	None	Outgoing Energy
Steam	“Sent” Flow Line	“Return” Flow Line (condensate)	Change in Energy
Steam	“Sent” Flow Line	None	Outgoing Energy

As above, you must properly configure the meter in the Energy Menu.

1. Loc in Sent Flow? Select Yes or No based on where the meter is located. Refer to the above table
2. Heating System? Select Yes for a hot water system used for heating. Select No for a chilled water system used for cooling. Always select Yes for a steam system.
3. % Returned. Select a number between 0% and 100%. Estimate the amount of water that returns. It is usually 100%, or can be less than 100% if historical data shows the amount of makeup water used. If a second RTD is not used, set to 0%. When 0% is selected, the energy calculation represents the outgoing energy only (no return energy is subtracted). **NOTE: the meter ships from the factory assuming 0% return and has a 1000 ohm resistor installed in the RTD #2 wiring location. This needs to be removed if the meter is to be used in a manner other than with 0% return and with the customer supplied RTD in its place.**

# Fluid Menu

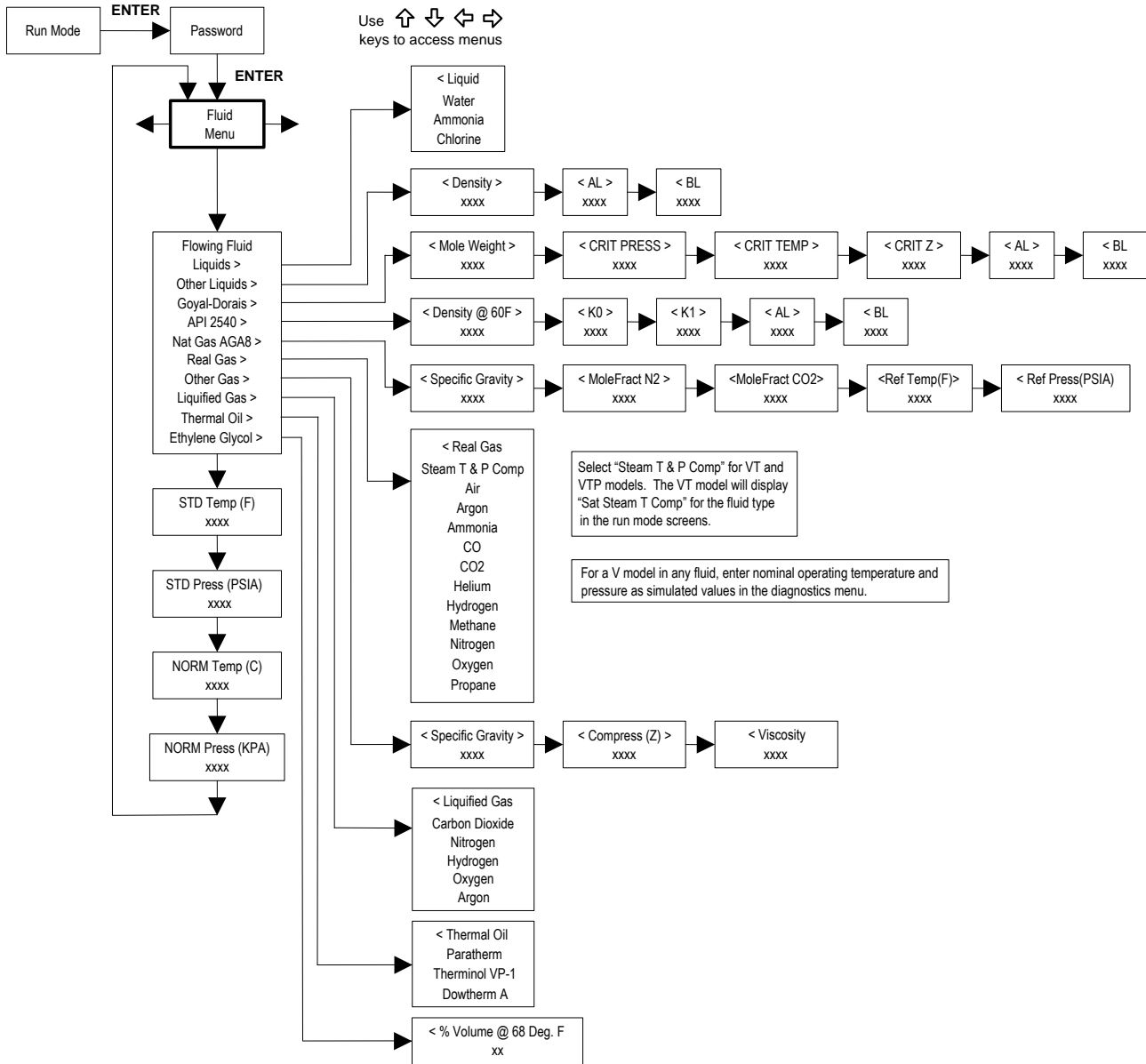

Use the Fluid Menu to configure the flow meter for use with common gases, liquids and steam. Your flow meter is pre-programmed at the factory for your application’s process fluid.

Reference Richard W. Miller, *Flow Measurement Engineering Handbook (Third Edition, 1996)*, page 2-75 for definition and use of the Goyal-Doraiswamy equation and page 2-76 for the definition and use of the API 2540 equation. Also, see Appendix C for Fluid Calculation equations.

The units of measurement used in the Fluid Menu are preset and are as follows:  
 Mole Weight = lb<sub>m</sub>/(lb<sub>m</sub>·mol), CRIT PRESS = psia, CRIT TEMP = °R, Density = lbm/ft<sup>3</sup> and Viscosity = cP (centipoise).

## Units Menu

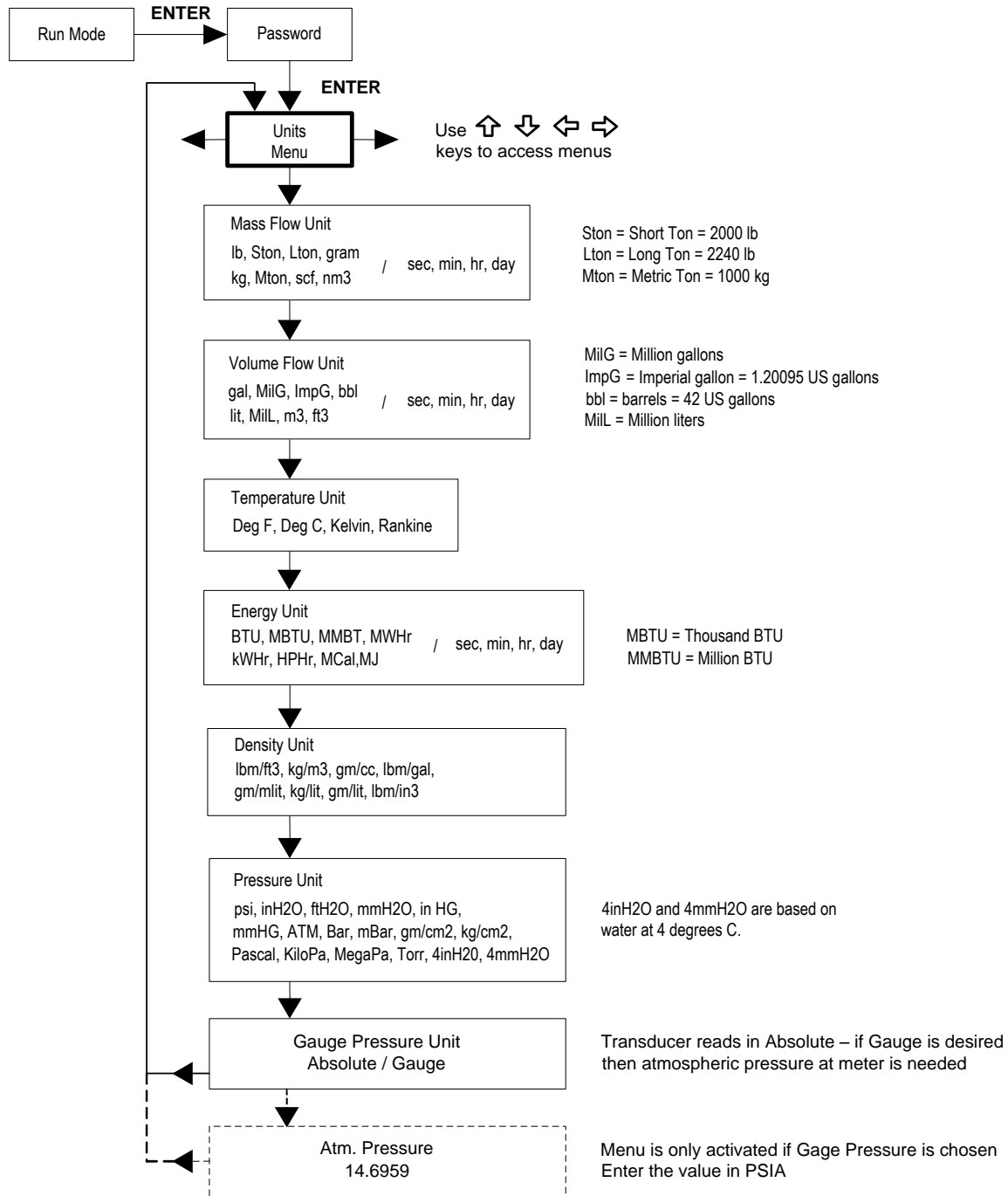

Use the Units Menu to configure the flow meter with the desired units of measurement. (These are global settings and determine what appears on all screens.)

## Time & Date Menu

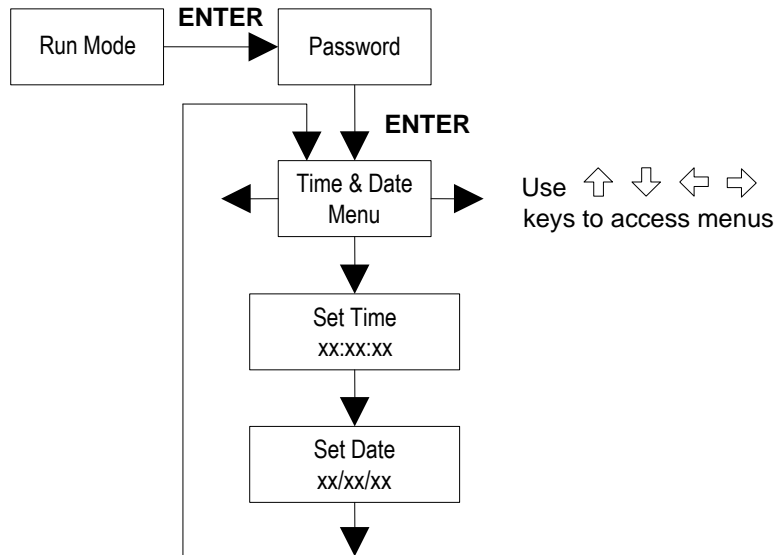

Use the Time and Date Menu to enter the correct time and date into the flow meter's memory. The parameters are used in the Run Mode and the alarm and system log files.

Note: Time is displayed in AM/PM format, but military format is used to set the time. For example, 1:00 PM is entered as 13:00:00 in the Set Time menu.

### Example for Setting the Time

How to set the time to 12:00:00. You can check the time in the Run Mode by pressing the keys until the Time & Date screen appears. Note: all outputs are disabled while using the Setup Menus.

1. Use keys to move to the Time and Date Menu.
2. Press key until Set Time appears. Press ENTER.
3. Press key until 1 appears. Press key to move the underline cursor to the next digit. Press the key until 2 appears. Continue sequence until all desired parameters are entered. Press ENTER to return to the Time and Date Menu.
4. Press **EXIT** to return to the Run Mode.



## Diagnostics Menu

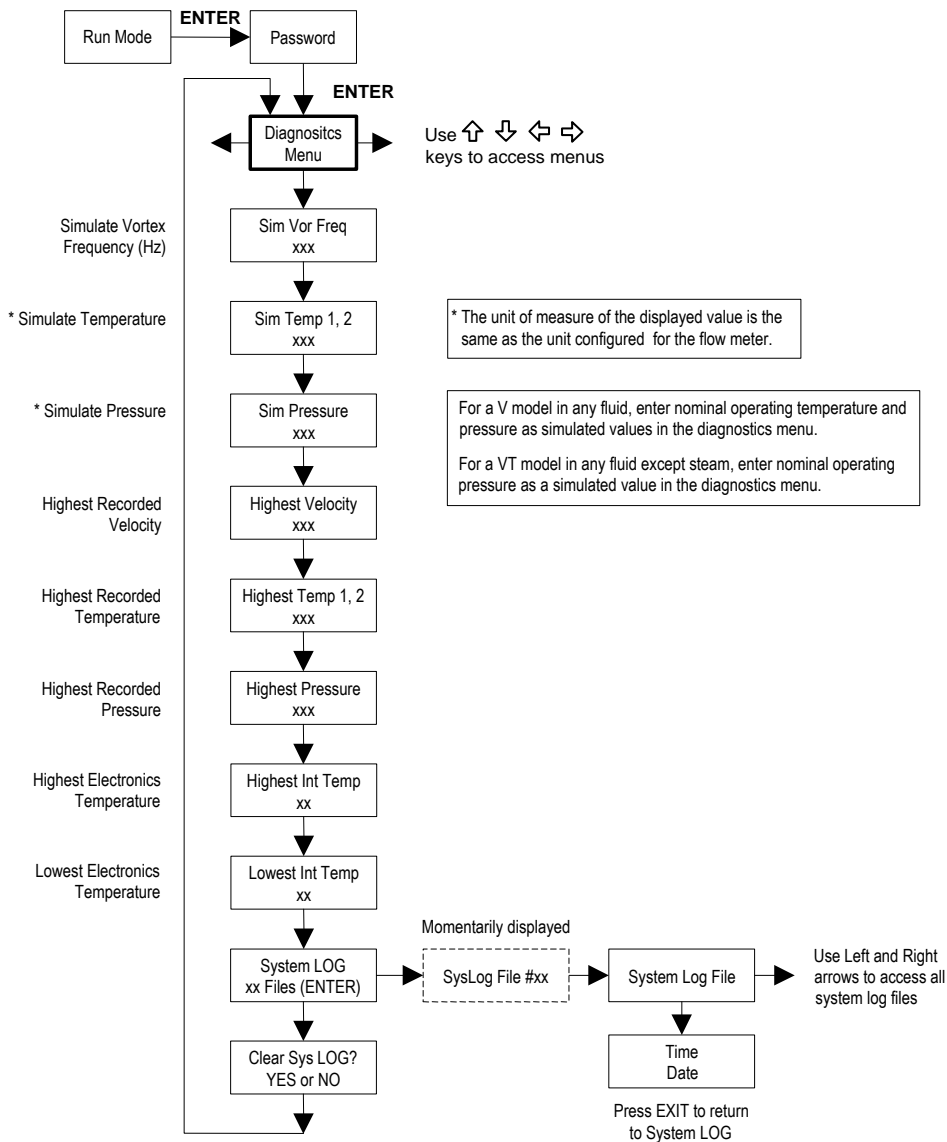

Use the Diagnostics Menu to simulate operation and review the system files. The system log files contain time/date stamped messages including: power on, power off, programming time outs, parameter faults, incorrect password entry and other various information relative to system operation and programming.

The simulated inputs are for testing the meter to verify that the programming is correct. They are also used to enter nominal operating temperature and pressure for the V only model. Simulated turbine frequency allows you to enter any value for the sensor input in Hz. The meter will calculate a flow rate based on the corresponding value and update all analog outputs (**the totalizer display and output is not affected by a simulated frequency**). The simulated pressure and temperature settings work the same way. The meter will output these new values and will use them to calculate a new density for mass flow measurement. Note: when your diagnostic work is complete, make sure to return the values to zero to allow the electronics to use the actual transducer values. For the V only model keep the temperature and pressure at nominal operating conditions.

If the meter display indicates a temperature or pressure fault, a substitute value can be entered to allow flow calculations to continue at a fixed value until the source of the fault is identified and corrected. The units of measure of the displayed values are the same as the units configured for the flow meter.

### Calibration Menu

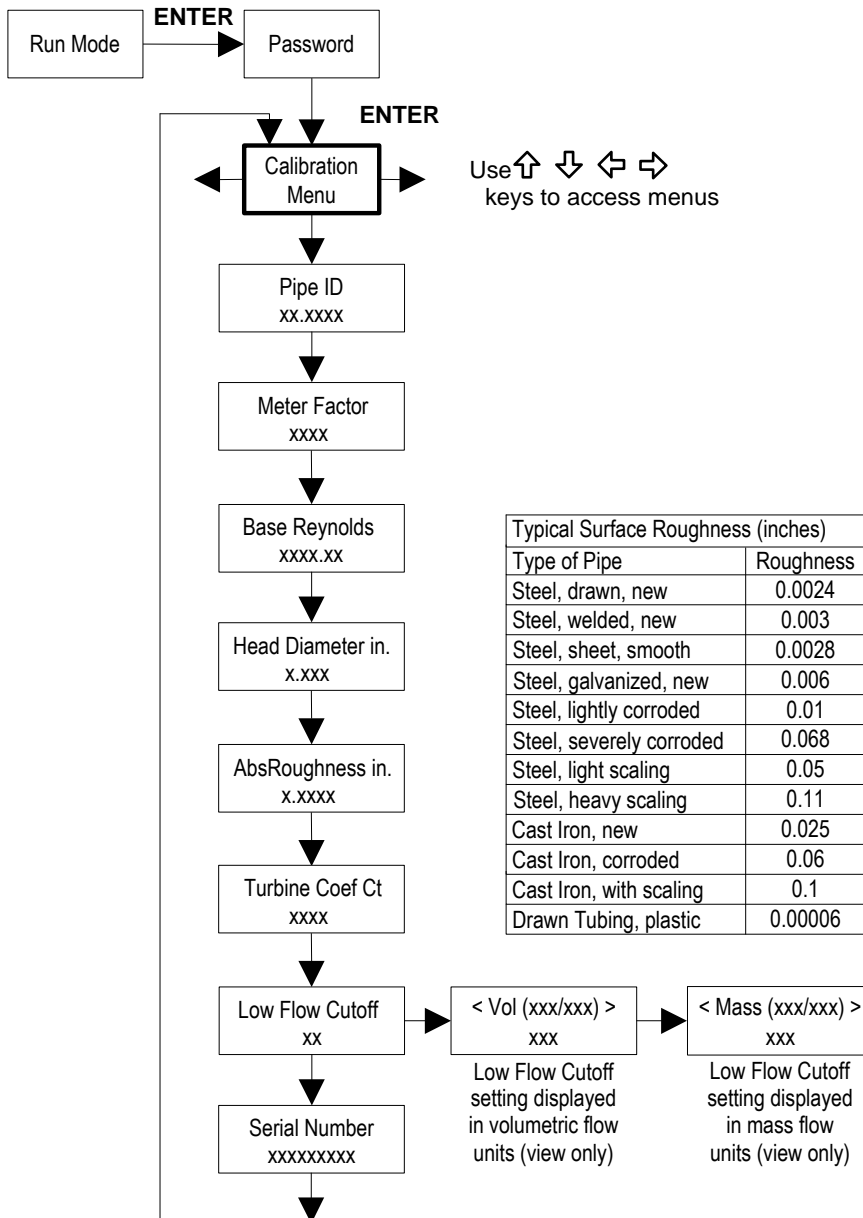

The Calibration Menu contains the calibration coefficients for the flow meter. These values should be changed only by properly trained personnel. The Low Flow Cutoff is set at the factory. Consult the factory for help with these settings if the meter is showing erratic flow rate.

### Password Menu

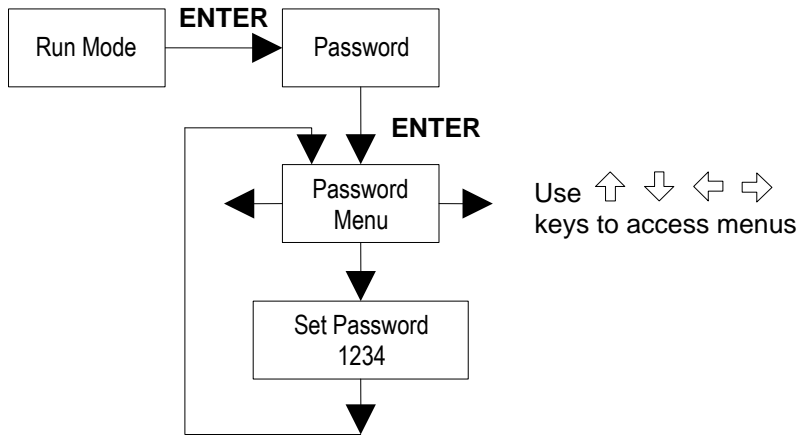

Use the Password Menu to set or change the system password. The factory-set password is 1234.

# Chapter 4 Serial Communications

## HART Communications

The HART Communications Protocol (Highway Addressable Remote Transducer Protocol) is a bidirectional digital serial communications protocol. The HART signal is based on the Bell 202 standard and is superimposed on 4-20 mA Output 1. Peer-to-peer (analog / digital) and multi-drop (digital only) modes are supported.

### Wiring

The diagrams below detail the proper connections required for HART communications:



**Warning!**  
Place controls in manual mode when making configuration changes to the turbine meter.

### Loop Powered Meter Wiring

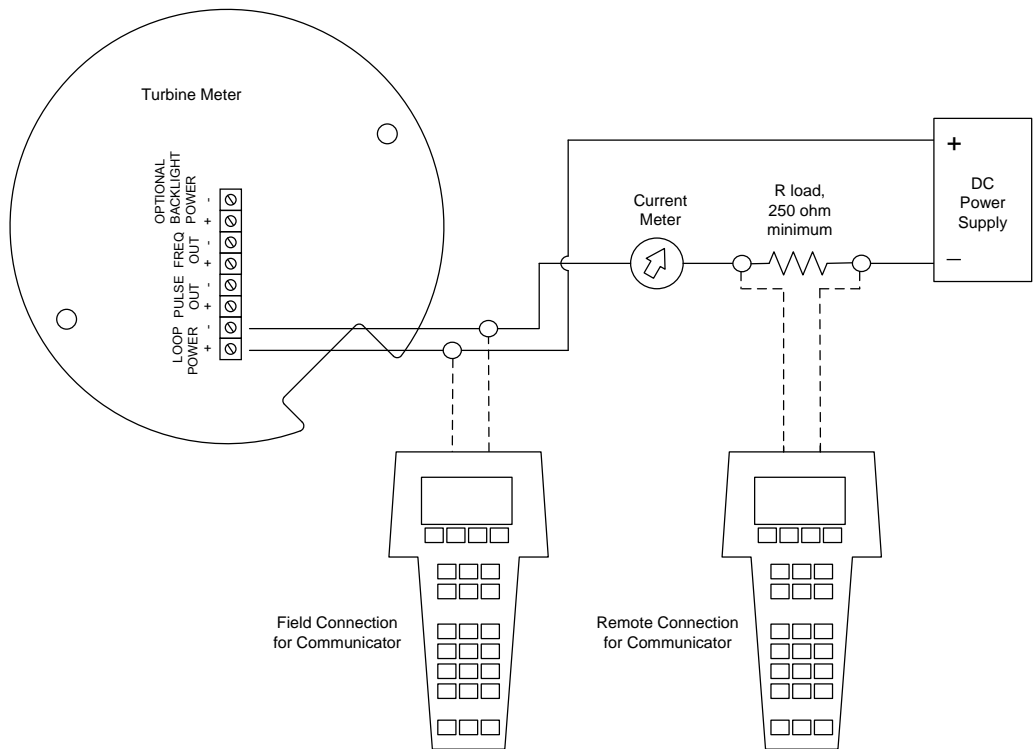

Figure 4-1. Loop Powered Meter Wiring (HART)

### DC Powered Meter Wiring

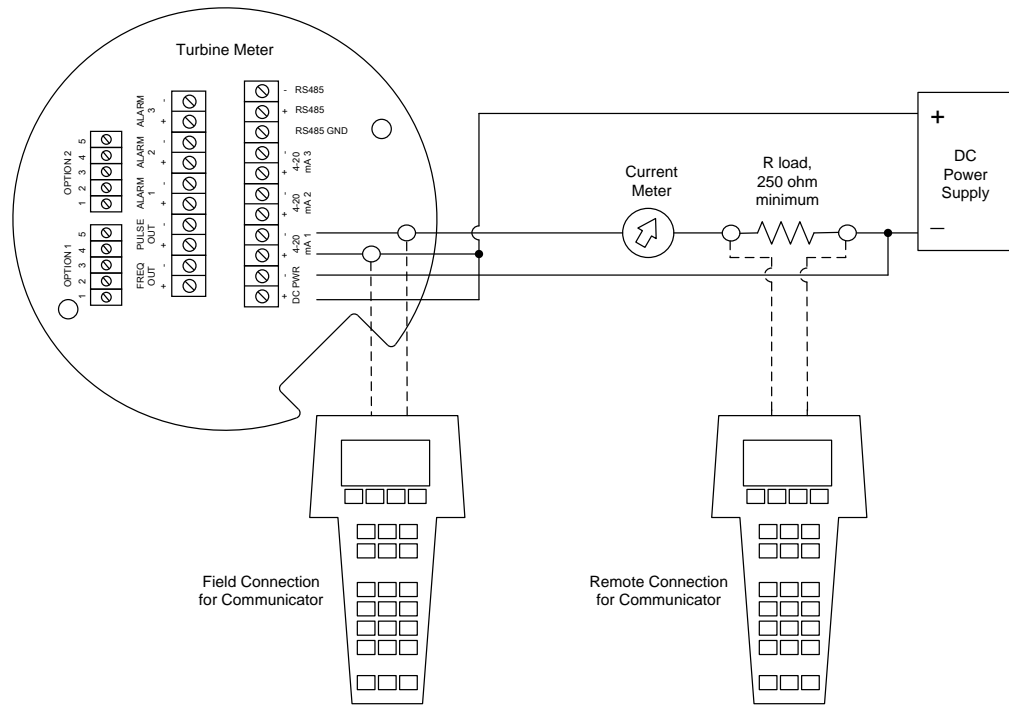

Figure 4-2. DC Powered Meter Wiring (HART)

### AC Powered Meter Wiring

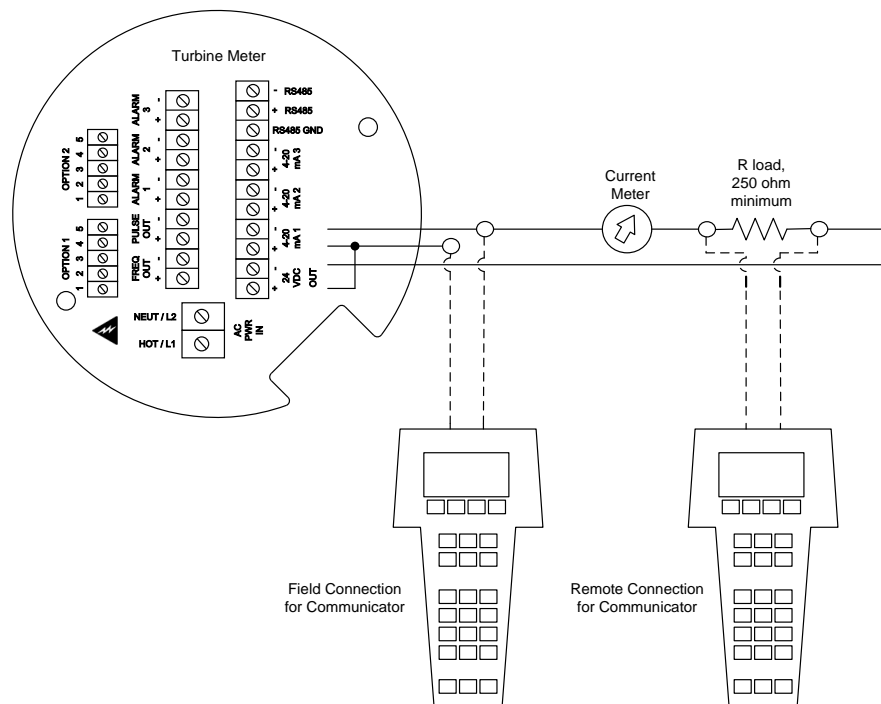
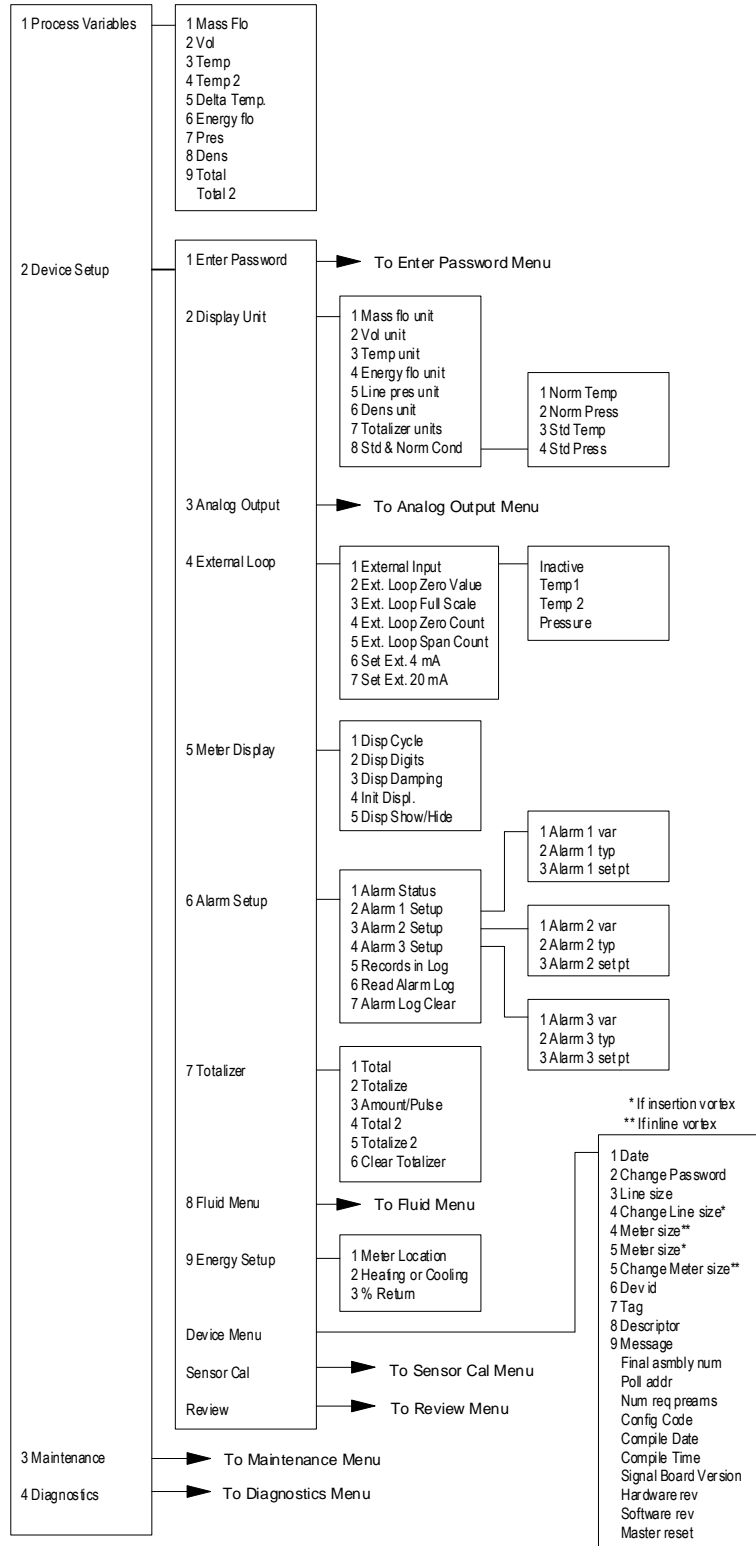

Figure 4-3. AC Powered Meter Wiring (HART)

# HART Commands with the DD Menu

## Online Menu



## HART Commands with the DD Menu Continued

### Analog Output Menu

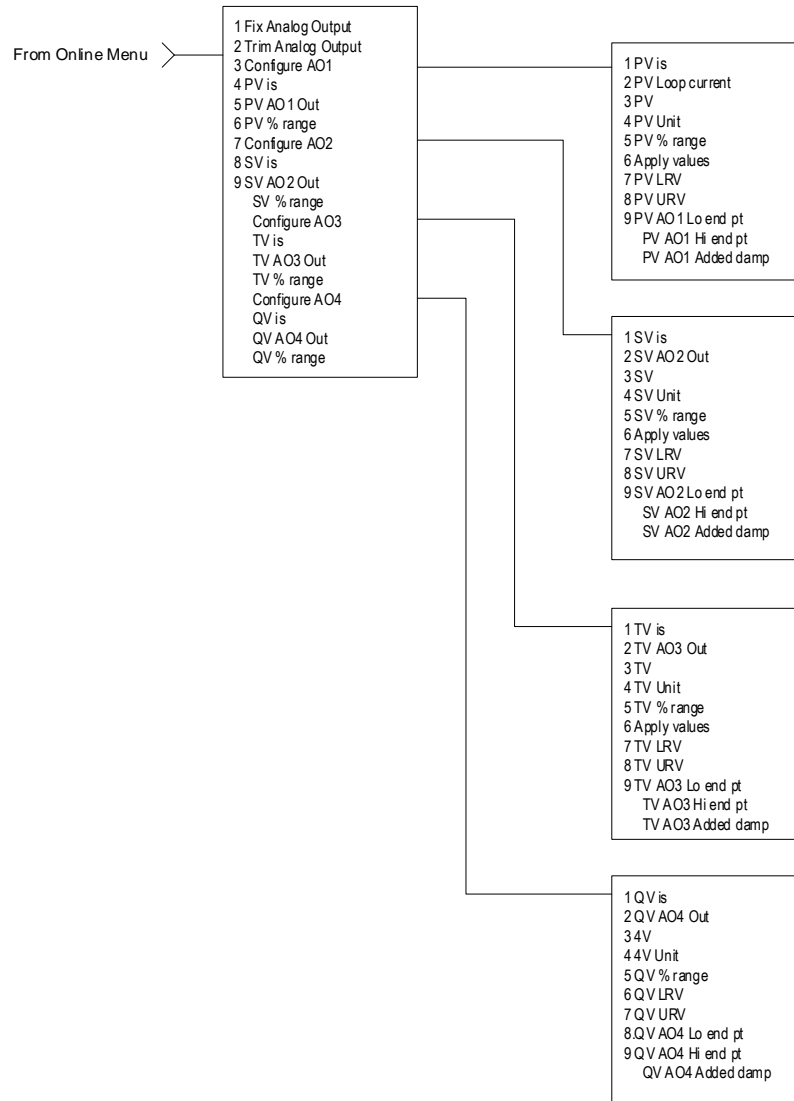

## HART Commands with the DD Menu Continued

### Fluid Menu

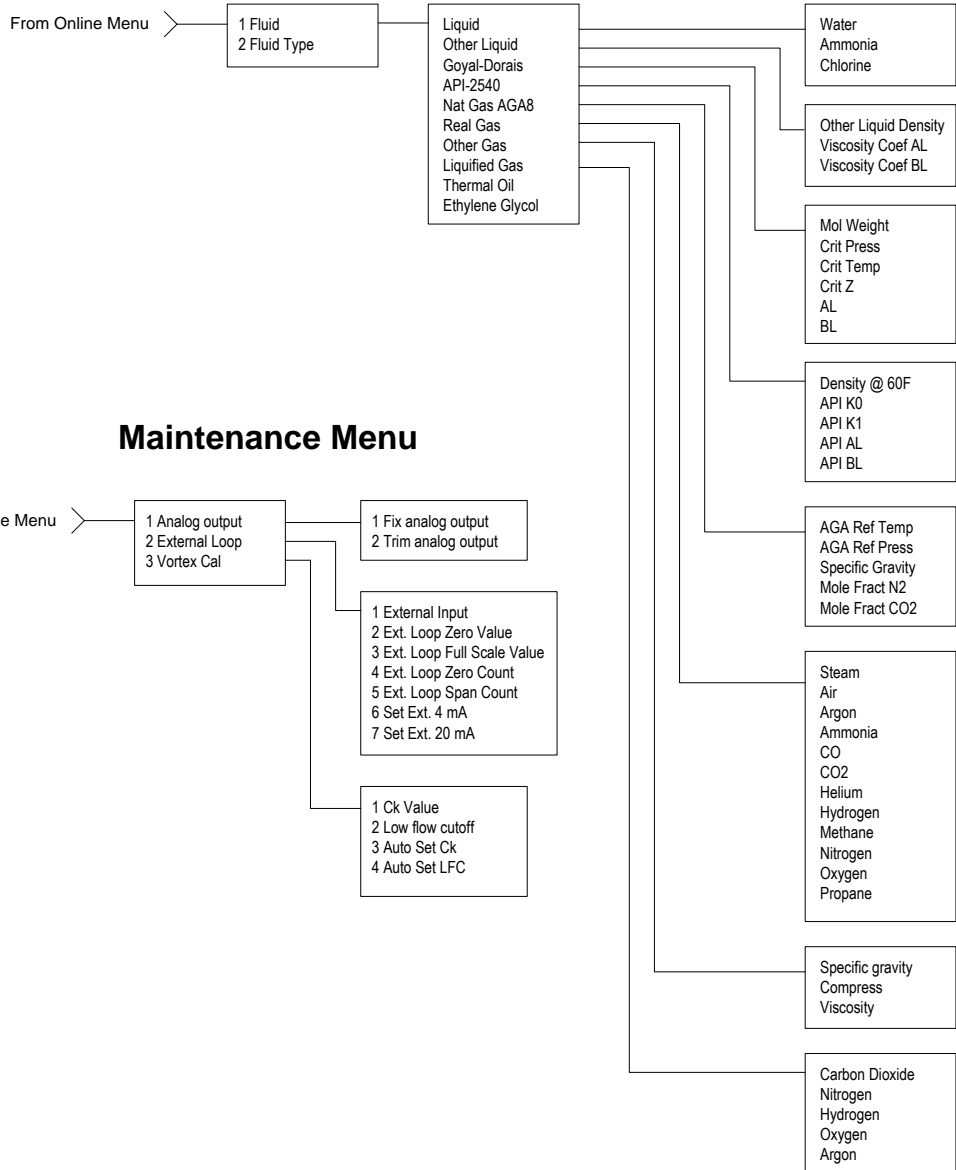



# HART Commands with the DD Menu Continued

## Diagnostics Menu

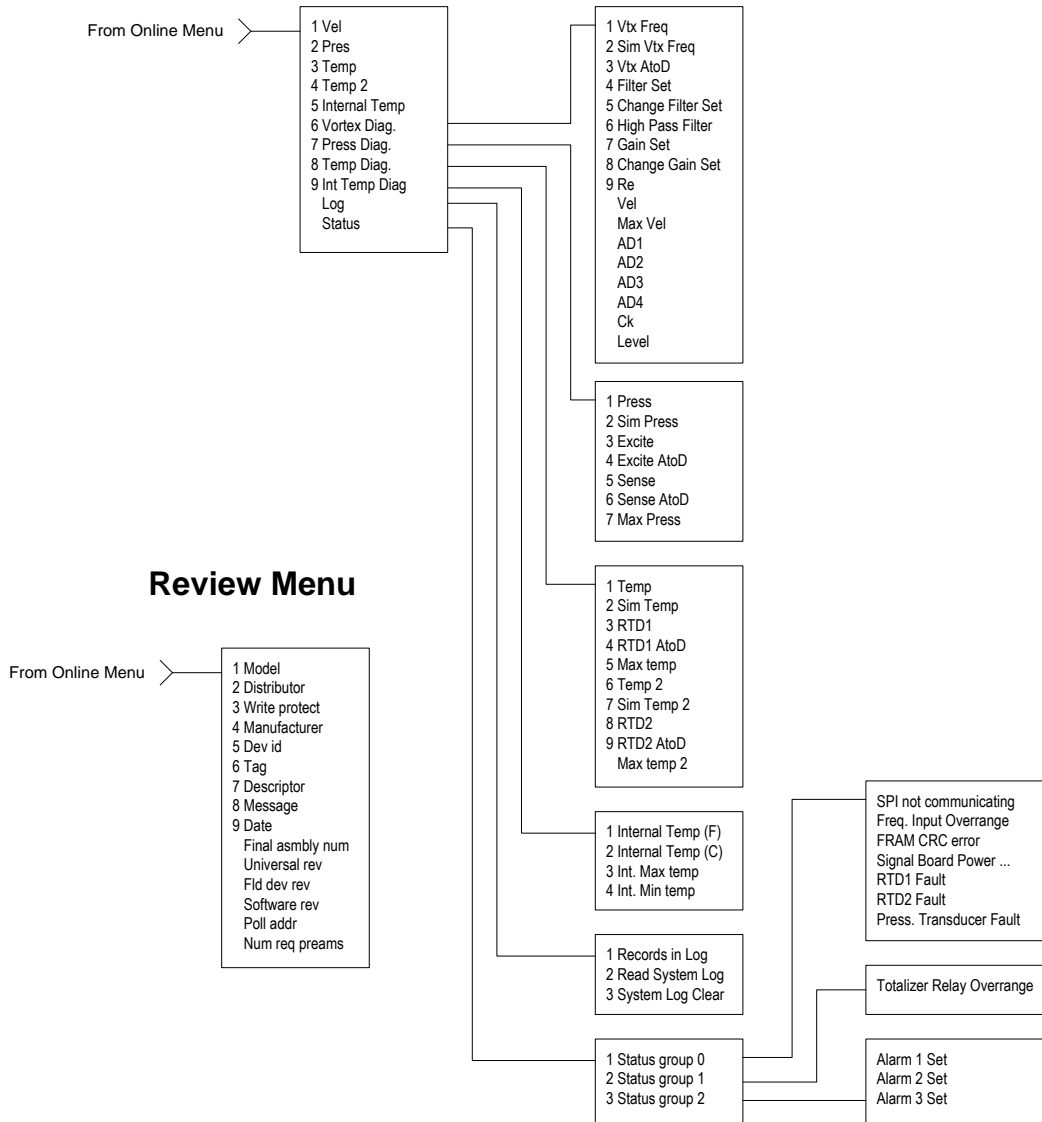

# HART Commands with the DD Menu Continued

## Sensor Cal Menu

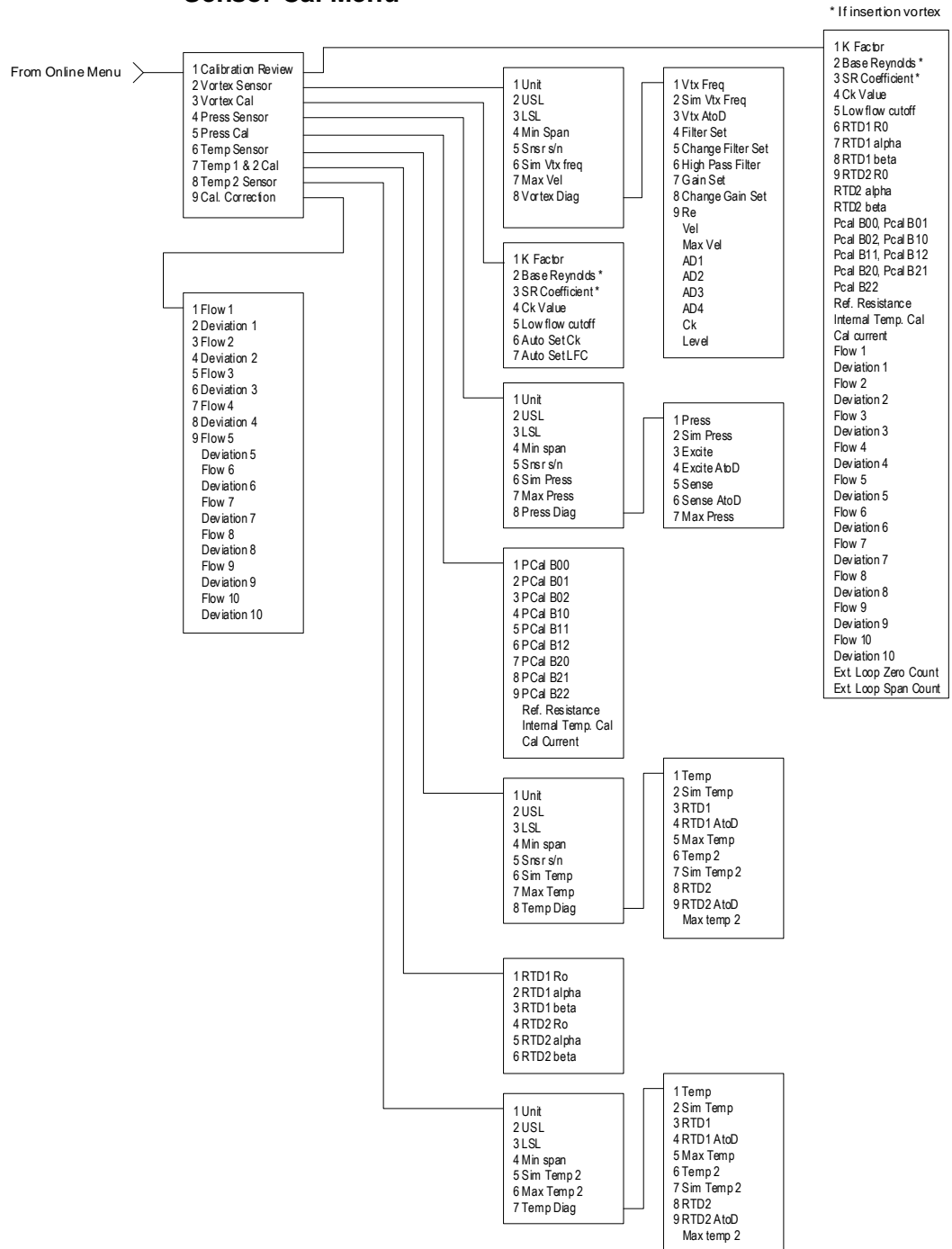

## HART Commands with Generic DD Menu

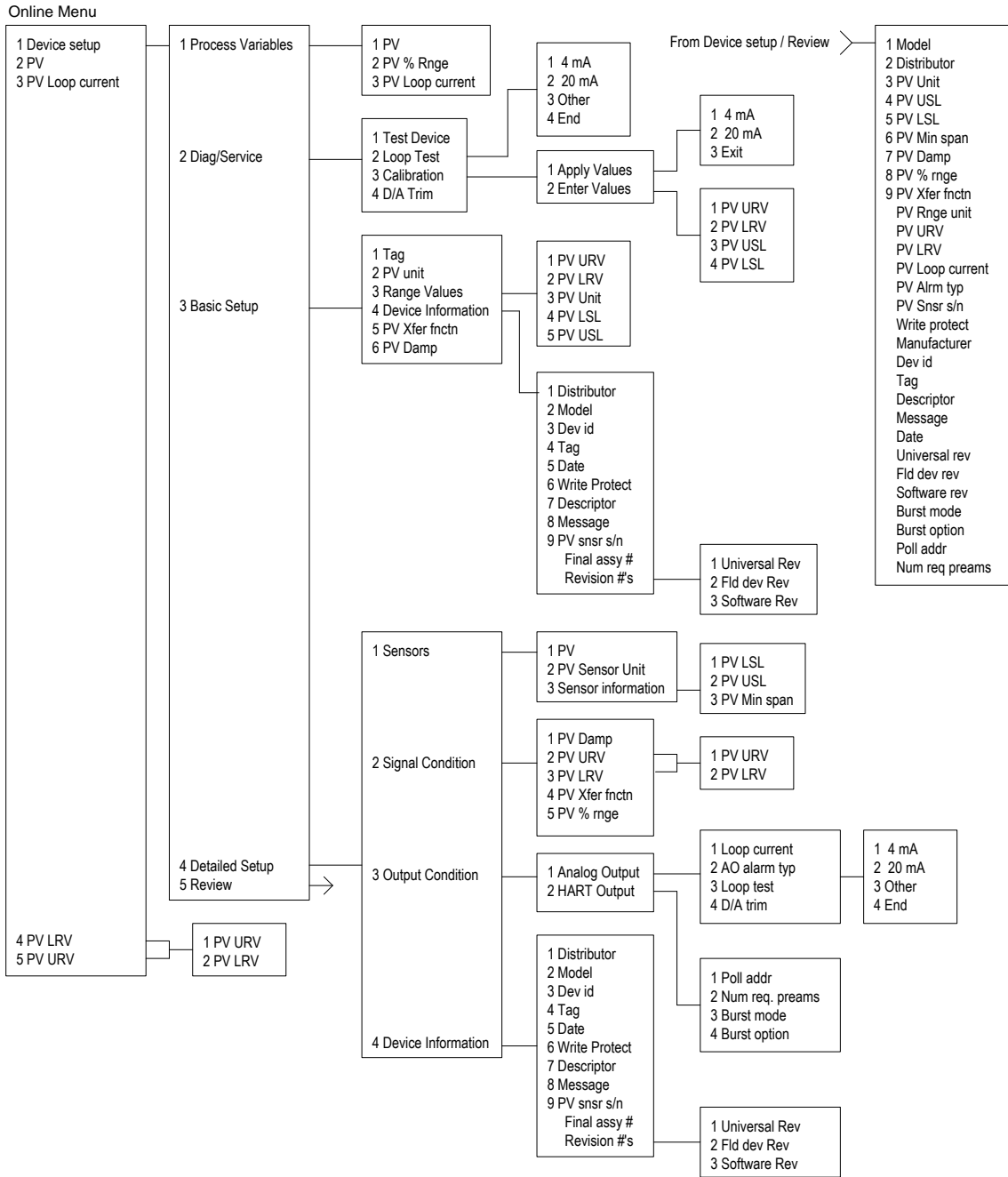

# Modbus Communications



## Warning!

Place controls in manual mode when making configuration changes to the turbine meter.

## Applicable Flow Meter Models

VorTek Pro-T™ Mass Flow Meters with Modbus communication protocol and firmware version 4.00.58 and above.

## Overview

This document describes the preliminary implementation of the Modbus communication protocol for use in monitoring common process variables in the VorTek Pro-T™ Insertion Turbine flow meter. The physical layer utilizes the half-duplex RS-485 port, and the Modbus protocol.

## Reference Documents

The following documents are available online from [www.modbus.org](http://www.modbus.org).

Modbus Application Protocol Specification V1.1

Modbus Over Serial Line Specification & Implementation Guide V1.0

Modicon Modbus Protocol Reference Guide PI-MBUS-300 Rev. J

## Wiring

An RS485 daisy chained network configuration as depicted below is recommended. Do not use a star, ring, or cluster arrangement.

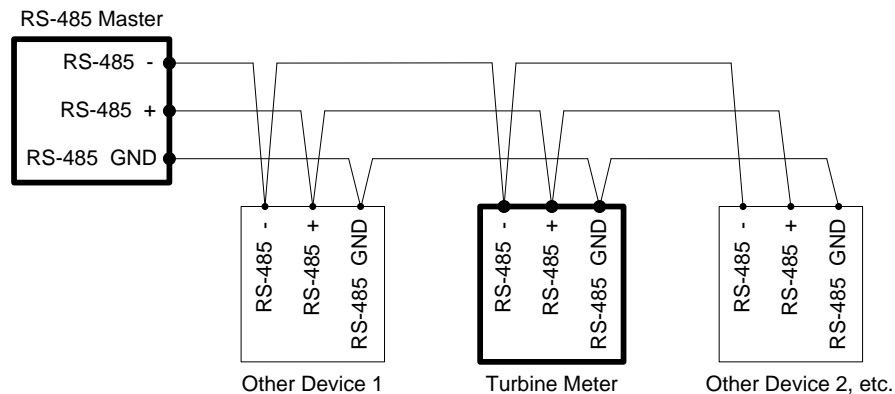

Figure 4-4. RS-485 Wiring (MODBUS)

## Pin Labeling (among devices)

“RS-485 -” = “A” = “TxD-/RxD-” = “Inverting pin”

“RS-485 +” = “B” = “TxD+/RxD+” = “Non-Inverting pin”

“RS-485 GND” = “GND” = “G” = “SC” = “Reference”

---

## Menu Items

The following menu items are in the Output Menu and allow selection and control of the Modbus communication protocol.

### Address

When the Modbus protocol is selected, the Modbus address is equal to the user programmable device address if it is in the range 1...247, in accordance with the Modbus specification. If the device address is zero or is greater than 247, then the Modbus address is internally set to 1.

### Comm Protocol

The Comm Protocol menu allows selection of “Modbus RTU Even,” “Modbus RTU Odd,” or “Modbus RTU None2,” or “Modbus RTU None1,” (non-standard Modbus) with Even, Odd and None referring to the parity selection. When even or odd parity is selected, the unit is configured for 8 data bits, 1 parity bit and 1 stop bit; with no parity, the number of stop bits is 1 (non-standard) or 2. When changing the protocol, the change is made as soon as the Enter key is pressed.

### Modbus Units

The Modbus Units menu is to control what units, where applicable, the meter's variables will be displayed in. Internal – these are the base units of the meter, °F, psia, lbm/sec, ft<sup>3</sup>/sec, Btu/sec, lbm/ft<sup>3</sup>. Display – variables are displayed in user selected display unit.

### Modbus Order

The byte order within registers and the order in which multiple registers containing floating point or long integer data are transmitted may be changed with this menu item. According to the Modbus specification, the most significant byte of a register is transmitted first, followed by the least significant byte. The Modbus specification does not prescribe the order in which registers are transmitted when multiple registers represent values longer than 16 bits. Using this menu item, the order in which registers representing floating point or long integer data and/or the byte order within the registers may be reversed for compatibility with some PLCs and PC software.

The following four selections are available in this menu; when selecting an item, the protocol is changed immediately without having to press the Enter key.

0-1:2-3	Most significant register first, most significant byte first (default)
2-3:0-1	Least significant register first, most significant byte first
1-0:3-2	Most significant register first, least significant byte first
3-2:1-0	Least significant register first, least significant byte first

*Table 4-1. Byte Order*

Note that all of the registers are affected by the byte order, including strings and registers representing 16-bit integers; the register order only affects the order of those registers representing 32-bit floating point and long integer data, but does not affect single 16-bit integers or strings.

## Modbus Protocol

The Modbus RTU protocol is supported in this implementation. Supported baud rates are 1200, 2400, 4800, 9600, 19200, 38400, 57600, and 115200. The default baud rate is 19200 baud. Depending upon the Modbus protocol selected, data are transmitted in 8-bit data frames with even or odd parity and 1 stop bit, or no parity and 2 or 1 (non-standard) stop bits.

The current Modbus protocol specification does not define register usage, but there is an informal register numbering convention derived from the original (now obsolete) Modicon Modbus protocol specification, and used by many vendors of Modbus capable products.

Registers	Usage	Valid Function Codes
00001–09999	Read/write bits ("coils")	01 (read coils) 05 (write single coil) 15 (write multiple coils)
10001–19999	Read-only bits ("discrete inputs")	02 (read discrete inputs)
30001–39999	Read-only 16 bit registers ("input registers"), IEEE 754 floating point register pairs, arbitrary length strings encoded as two ASCII characters per 16-bit register	03 (read holding registers) 04 (read input registers)
40001–49999	Read/write 16-bit registers ("holding registers"), IEEE 754 floating point register pairs, arbitrary length strings encoded as two ASCII characters per 16-bit register	03 (read holding registers) 06 (write single register) 16 (write multiple registers)

Each range of register numbers maps to a unique range of addresses that are determined by the function code and the register number. The address is equal to the least significant four digits of the register number minus one, as shown in the following table.

Registers	Function Codes	Data Type and Address Range
00001-09999	01, 05, 15	Read/write bits 0000-9998
10001-19999	02	Read-only bits 0000-9999
30001-39999	03, 04	Read-only 16-bit registers 0000-9998
40001-49999	03, 06, 16	Read/write 16-bit registers 0000-9998

## Register Definitions

The meter serial number and those variables that are commonly monitored (mass, volume and energy flow rates, total, pressure, temperature, density, viscosity, Reynolds number, and diagnostic variables such as frequency, velocity, gain, amplitude and filter setting) are accessible via the Modbus protocol. Long integer and floating point numbers are accessed as pairs of 16-bit registers in the register order selected in the Modbus Order menu. Floating point numbers are formatted as single precision IEEE 754 floating point values.

The flow rate, temperature, pressure, and density variables may be accessed as either the flow meter internal base units or in the user-programmed display units, which is determined by the programming Output Menu's "Modbus Units" item. The display units strings may be examined by accessing their associated registers. Each of these units string registers contain 2 characters of the string, and the strings may be 2 to 12 characters in length with unused characters set to zero. Note that the byte order affects the order in which the strings are transmitted. If the Modbus Order menu (see page 2) is set to 0-1:2-3 or 2-3:0-1, then the characters are transmitted in the correct order; if set to 1-0:3-2 or 3-2:1-0, then each pair of characters will be transmitted in reverse order.

Registers	Variable	Data type	Units	Function code	Addresses
65100-65101	Serial number	unsigned long	—	03, 04	
30525-30526	Totalizer	unsigned long	display units*	03, 04	524-525
32037-32042	Totalizer units	string	—	03, 04	2036-2041
30009-30010	Mass flow	float	display units*	03, 04	8-9
30007-30008	Volume flow	float	display units*	03, 04	6-7
30005-30006	Pressure	float	display units*	03, 04	4-5
30001-30002	Temperature	float	display units*	03, 04	0-1
30029-30030	Velocity	float	ft/sec	03, 04	28-29
30015-30016	Density	float	display units*	03, 04	14-15
30013-30014	Viscosity	float	cP	03, 04	12-13
30031-30032	Reynolds number	float	—	03, 04	30-31
30025-30026	Turbine frequency	float	Hz	03, 04	24-25
34532	Gain	char	—	03, 04	4531
30085-30086	Turbine amplitude	float	Vrms	03, 04	84-85
30027-30028	Filter setting	float	Hz	03, 04	26-27

Table 4-2. Register Definitions

The following registers are available with the energy meter firmware:

Registers	Variable	Data type	Units	Function code	Addresses
30527-30528	Totalizer #2	unsigned long	display units*	03, 04	526-527
32043-32048	Totalizer #2 units	string	—	03, 04	2042-2047
30003-30004	Temperature #2	float	display units*	03, 04	2-3
30011-30012	Energy flow	float	display units*	03, 04	10-11

The following registers contain the display units strings:

Registers	Variable	Data type	Units	Function code	Addresses
32007-32012	Volume flow units	string	—	03, 04	2006-2011
32001-32006	Mass flow units	string	—	03, 04	2000-2005
32025-32030	Temperature units	string	—	03, 04	2024-2029
32019-32024	Pressure units	string	—	03, 04	2018-2023
32031-32036	Density units	string	—	03, 04	2030-2035
32013-32017	Energy flow units	string	—	03, 04	2012-2017

Function codes 03 (read holding registers) and 04 (read input registers) are the only codes supported for reading these registers, and function codes for writing holding registers are not implemented. We recommend that the floating point and long integer registers be read in a single operation with the number of registers being a multiple of two. If these data are read in two separate operations, each reading a single 16-bit register, then the value will likely be invalid.



The floating point registers with values in display units are scaled to the same units as are displayed, but are instantaneous values that are not smoothed. If display smoothing is enabled (non-zero value entered in the Display TC item in the Display Menu), then the register values will not agree exactly with the displayed values.

## Exception Status Definitions

The Read Exception Status command (function code 07) returns the exception status byte, which is defined as follows. This byte may be cleared by setting “coil” register #00008 (function code 5, address 7, data = 0xff00).

Bit(s)	Definition
0-1	Byte order (see Modbus Order on page 2) 0 = 3-2:1-0 1 = 2-3:0-1 2 = 1-0:3-2 3 = 0-1:2-3
2	Not used
3	Not used
4	Not used
5	Not used
6	Not used
7	Configuration changed

## Discrete Input Definitions

The status of the three alarms may be monitored via the Modbus Read Discrete Input command (function code 02). The value returned indicates the state of the alarm, and will be 1 only if the alarm is enabled and active. A zero value is transmitted for alarms that are either disabled or inactive,

Registers	Variable	Function Code	Address
10001	Alarm #1 state	02	0
10002	Alarm #2 state	02	1
10003	Alarm #3 state	02	2

## Control Register Definitions

The only writeable registers in this implementation are the Reset Exception Status, Reset Meter and Reset Totalizer functions, which are implemented as "coils" which may be written with the Write Single Coil command (function code 05) to address 7 through 9, respectively, (register #00008 through #00010). The value sent with this command must be either 0x0000 or 0xff00, or the meter will respond with an error message; the totalizer will be reset or exception status cleared only with a value of 0xff00.

## Error Responses

If an error is detected in the message received by the unit, the function code in the response is the received function code with the most significant bit set, and the data field will contain the exception code byte, as follows:

Exception Code	Description
01	Invalid function code — function code not supported by device
02	Invalid data address — address defined by the start address and number of registers is out of range
03	Invalid data value — number of registers = 0 or >125 or incorrect data with the Write Single Coil command

If the first byte of a message is not equal to the unit's Modbus address, if the unit detects a parity error in any character in the received message (with even or odd parity enabled), or if the message CRC is incorrect, the unit will not respond.

## Command Message Format

The start address is equal to the desired first register number minus one. The addresses derived from the start address and the number of registers must all be mapped to valid defined registers, or an invalid data address exception will occur.

Device Address	Function Code	Start Address	N = Number of Registers	CRC
8 bits, 1...247	8 bits	16 bits, 0...9998	16 bits, 1...125	16 bits

## Normal Response Message Format

Device Address	Function Code	Byte Count = 2 x N	Data	CRC
8 bits, 1...247	8 bits	8 bits	(N) 16-bit registers	16 bits

## Exception Response Message Format

Device Address	Function Code + 0x80	Exception Code	CRC
8 bits, 1...247	8 bits	8 bits	16 bits

### Examples

Read the exception status byte from the device with address 1:

```
01 07 41 E2
```

```
01 Device address
07 Function code, 07 = read exception status
41 E2 CRC
```

A typical response from the device is as follows:

```
01 07 03 62 31
```

```
01 Device address
07 Function code
03 Exception status byte
62 31 CRC
```

Request the first 12 registers from device with address 1:

```
01 04 00 00 00 0C F0 0F
```

```
01 Device address
04 Function code, 04 = read input register
00 00 Starting address
00 0C Number of registers = 12
F0 0F CRC
```

A typical response from the device is as follows: \*note these are the older register definitions

```
01 04 18 00 00 03 E8 00 00 7A 02 6C 62 00 00 41 BA 87 F2 3E BF
FC 6F 42 12 EC 8B 4D D1
```

```
01 Device address
04 Function code
18 Number of data bytes = 24
00 00 03 E8 Serial number = 1000 (unsigned long)
00 00 7A 02 Totalizer = 31234 lbm (unsigned long)
6C 62 00 00 Totalizer units = "lb" (string, unused characters
are 0)
41 BA 87 F2 Mass flow rate = 23.3164 lbm/sec (float)
3E BF FC 6F Volume flow rate = 0.3750 ft3/sec (float)
42 12 EC 8B Pressure = 36.731 psia (float)
4D D1 CRC
```

**An attempt to read register(s) that don't exist**

```
01 04 00 00 00 50 F1 D2
```

```
01 Device address
04 Function code 4 = read input register
00 00 Starting address
00 50 Number of registers = 80
F0 36 CRC
```

**results in an error response as follows:**

```
01 84 02 C2 C1
```

```
01 Device address
84 Function code with most significant bit set indicates
error response
02 Exception code 2 = invalid data address
C2 C1 CRC
```

**Request the state all three alarms:**

```
01 02 00 00 00 03 38 0B
```

```
01 Device address
02 Function code 2 = read discrete inputs
00 00 Starting address
00 03 Number of inputs = 3
38 0B CRC
```

**and the unit responds with:**

```
01 02 01 02 20 49
```

```
01 Device address
02 Function code
01 Number of data bytes = 1
02 Alarm #2 on, alarms #1 and #3 off
20 49 CRC
```

**To reset the totalizer:**

```
01 05 00 00 FF 00 8C 3A
```

```
01 Device address
05 Function code 5 = write single coil
00 09 Coil address = 9
FF 00 Data to reset totalizer
5C 38 CRC
```

The unit responds with an identical message to that transmitted, and the totalizer is reset. If the “coil” is turned off as in the following message, the response is also identical to the transmitted message, but the totalizer is not affected.

```
01 05 00 09 00 00 1D C8
```

```
01 Device address  
05 Function code 5 = write single coil  
00 09 Coil address = 9  
00 00 Data to “turn off coil” does not reset totalizer  
1D C8 CRC
```

---

## BACnet MS/TP Communications

### 1. BACnet MS/TP Description

The BACnet Master-Slave/Token-Passing (MSTP) driver implements a data link protocol that uses the services of the RS-485 physical layer. The MS/TP bus is based on BACnet standard protocol SSPC-135, Clause 9. BACnet MS/TP protocol is a peer-to-peer, multiple master protocols based on token passing. Only master devices can receive the token, and only the device holding the token is allowed to originate a message on the bus. The token is passed from master device to master device using a small message. The token is passed in consecutive order starting with the lowest address. Slave devices on the bus only communicate on the bus when responding to a data request from a master device.

### 2. Baud Rates on the MS/TP Bus

An MS/TP bus can be configured to communicate at one of four different baud rates. It is very important that all of the devices on an MS/TP bus communicate at the same baud rate. The baud rate setting determines the rate at which devices communicate data over the bus. The baud rate settings available on Pro-T™ Insertion Turbine Mass Flow Meters are 9600, 19200 and 38400.

#### ***2.1. Baud Rate and MAC address configuration***

1. Power on the IUT
2. Press Enter to go to the configuration menu
3. Enter the factory password 16363 (Use Up and Down arrows to enter the digits)
4. Navigate with the left arrow to Diagnostics menu
5. Press Enter and press right button immediately
6. Navigate to Config Code screen by continuous pressing down button
7. After reaching config code screen, press right to navigate to Comm. Type screen
8. Change the comm. Type to "BACnet" and press Enter

Note: BACnet will enable Baud Rate and MAC address screens
9. Press Exit twice to go back to the Diagnostics menu
10. Navigate to Output Menu by using right or left arrow buttons
11. Press Down button and reach Baud Rate and MAC address screens

12. Change the required settings and press Exit & Enter buttons to save the configuration
13. Reboot the device by power off and on for the changes to take effect

**Note:**

- a. IUT support 9600, 19200, 38400 baud rates
- b. MAC address range is 0-127

**3. Supported BACnet Objects**

A BACnet object represents physical or virtual equipment information, as a digital input or parameters. The Pro-T™ Insertion Turbine Mass Flow Meters presents the following object types:

- a. Device Object
- b. Analog Input
- c. Binary Input
- d. Binary Value

Each object type defines a data structure composed by properties that allow the access to the object information. The below table shows the implemented properties for each Turbine Flow Meters object type.

Properties	Object Types			
	Device	Analog Input	Binary Input	Binary Value
Object_Identifier	<input checked="" type="checkbox"/>	<input checked="" type="checkbox"/>	<input checked="" type="checkbox"/>	<input checked="" type="checkbox"/>
Object_Name	<input checked="" type="checkbox"/>	<input checked="" type="checkbox"/>	<input checked="" type="checkbox"/>	<input checked="" type="checkbox"/>
Object_Type	<input checked="" type="checkbox"/>	<input checked="" type="checkbox"/>	<input checked="" type="checkbox"/>	<input checked="" type="checkbox"/>
System_Status	<input checked="" type="checkbox"/>			
Vendor_Name	<input checked="" type="checkbox"/>			
Vendor_Identifier	<input checked="" type="checkbox"/>			
Model_Name	<input checked="" type="checkbox"/>			
Firmware_Revision	<input checked="" type="checkbox"/>			
Application-Software-Version	<input checked="" type="checkbox"/>			
Protocol_Version	<input checked="" type="checkbox"/>			
Protocol_Revision	<input checked="" type="checkbox"/>			
Protocol_Services_Supported	<input checked="" type="checkbox"/>			

Protocol_Object_Types_Supported	<input checked="" type="checkbox"/>			
Object_List	<input checked="" type="checkbox"/>			
Max_ADPU_Length_Accepted	<input checked="" type="checkbox"/>			
Segmentation_Supported	<input checked="" type="checkbox"/>			
ADPU_Timeout	<input checked="" type="checkbox"/>			
Number_Of_ADPU_Retries	<input checked="" type="checkbox"/>			
Max_Masters	<input checked="" type="checkbox"/>			
Max_Info_Frames	<input checked="" type="checkbox"/>			
Device_Address_Binding	<input checked="" type="checkbox"/>			
Database_Revision	<input checked="" type="checkbox"/>			
Status_Flags				
Event_State		<input checked="" type="checkbox"/>	<input checked="" type="checkbox"/>	<input checked="" type="checkbox"/>
Reliability				
Out_Of_Service		<input checked="" type="checkbox"/> (W)	<input checked="" type="checkbox"/> (W)	<input checked="" type="checkbox"/> (W)
Units		<input checked="" type="checkbox"/>		
Polarity			<input checked="" type="checkbox"/> (W)	
Priority_Array				
Relinquish_Default				
Status_Flag		<input checked="" type="checkbox"/>	<input checked="" type="checkbox"/>	<input checked="" type="checkbox"/>
Present_Value		<input checked="" type="checkbox"/> (W)	<input checked="" type="checkbox"/> (W)	<input checked="" type="checkbox"/> (W)
Inactive_Text				
Active_Text				

(W) – Writable Property.

### 3.1. Device Object:

The Device object default property values are as follows –

Property Name	Default Values
object-identifier	7
object-name	Device,1
object-type	Device
system-status	operational
vendor-name	VorTek Instruments
vendor-identifier	558
model-name	Multivariable Flowmete
firmware-revision	N/A
application-software-version	1.07
protocol-version	1
protocol-revision	4
protocol-services-supported	{F,F,F,F,F,F,F,F,F,F,F,T,F,T,T,T,F,F,F,F,F,F,F,F,F,F,T,T,F,F,F,F,F}



protocol-object-types-supported	{T,F,F,T,F,T,F,F,T,F,F,F,F,F,F,F,F,F,F,F,F,F}
object-list	{(analog-input,1),(analog-input,2),(analog-input,3),(analog-input,4),(analog-input,5),(analog-input,6),(analog-input,7),(analog-input,8)(analog-input,9),(analog-input,10),(analog-input,11),(analog-input,12),(analog-input,13),(analog-input,14),(analog-input,15),(analog-input,16),(analog-input,17),(analog-input,18),(analog-input,19),(binary-input,1),(binary-input,2),(binary-input,3),(binary-input,4),(binary-value,1),(device,7)}
max-apdu-length-accepted	300
segmentation-supported	no-segmentation
apdu-timeout	3000
number-of-APDU-retries	1
max-master	127
max-info-frames	1
device-address-binding	()
database-revision	0

Note - Device Communication Control: Password – “vortek”

### 3.2. Analog Input Object:

Turbine Mass Flow Meters Analog Input type objects are described in the below Table –

Object Instance	Object Name	Unit	Description
1	Volume Flow	cubic-feet-per-second, cubic-feet-per-minute, us-gallons-per-minute, imperial-gallons-per-minute, liters-per-minute, liters-per-second, liters-per-hour, cubic-meters-per-second, cubic-meters-per-minute, cubic-meters-per-hour	This AI object is used to measure volume flow.
2	Mass Flow	pounds-mass-per-second, grams-per-second, kilograms-per-second, kilograms-per-minute, kilograms-per-hour, pounds-mass-per-minute,	This AI object is used to measure mass flow.

		pounds-mass-per-hour, tons-per-hour, grams-per-second , grams-per-minute	
3	Temperature 1	degrees-Celsius, degrees-Kelvin, degrees-Fahrenheit	This AI object measures Temperature in one of the given Unit.
4	Temperature 2	degrees-Celsius, degrees-Kelvin, degrees-Fahrenheit	This AI object measures Temperature in one of the given Unit.
5	Pressure	pounds-force-per-square- inch, inches-of-water, inches-of-mercury, millimeters-of-mercury, bars, millibars, pascals, kilopascals	TBD
6	Density	kilograms-per-cubic-meter	TBD
7	Energy Flow	Kilowatts, Horsepower, btus-per-hour,, kilo-btus-per-hour, megawatts	TBD
8	Totalizer 1 & Totalizer 2	If Totalizer selection for Mass measure – pounds-mass-per-second, grams-per-second, kilograms-per-second , kilograms-per-minute , kilograms-per-hour, pounds-mass-per-minute , pounds-mass-per-hour, tons-per-hour, grams-per-second , grams-per-minute If Totalizer selection for Volume measure – cubic-feet-per-second, cubic-feet-per-minute, us-gallons-per-minute, imperial-gallons-per-	An electronic counter which records the total accumulated flow over a certain range of time.

		minute, liters-per-minute, liters-per-second, liters-per-hour, cubic-meters-per-second, cubic-meters-per-minute, cubic-meters-per-hour If Totalizer selection for Energy measure – Kilowatts, Horsepower, btus-per-hour,, kilo-btus-per-hour, megawatts	
10	StatusRegister	NO UNITS	TBD
11	Channel 1 (4-20mA)	milliamperes	TBD
12	Channel 2 (4-20mA)	milliamperes	TBD
13	Channel 3 (4-20mA)	milliamperes	TBD
14	Scaled Freq	hertz	TBD
15	Flow Velocity	feet-per-second	TBD
16	Viscosity	centipoises	TBD
17	Frequency	hertz	TBD
18	Turbine Amp	millivolts	TBD
19	FilterSetting	hertz	TBD

**3.3. Binary Input Object:**

Turbine Mass Flow Meters Binary Input type objects are described in the below Table.

Object Instance	Object Name	Description
1	Alarm1	The status of the three alarms may be monitored via the Modbus command. The value returned indicates the state of the alarm, and will be 1 only if the alarm is enabled and active. A zero value is transmitted for alarms that are either disabled or inactive
2	Alarm2	
3	Alarm3	
4	External	TBD

Note - Binary Input 4, Present value always read zero, because no information available from client, so the polarity property doesn't impact on Present value property when the Out of service property is false.

**3.4. Binary Value Object:**

Turbine Mass Flow Meters Binary Value type objects are described in the below Table.

Object Instance	Object Name	Description
1	Reset	Reset's Totalizer

#### 4. ANNEX - BACnet PROTOCOL IMPLEMENTATION CONFORMANCE STATEMENT

**Date:** 19-April-2012

**Vendor Name:** VorTek Instruments

**Product Name:** Turbo-Pro Pro-T multivariable flow-meter

**Product Model Number:** Pro-T VT/VTP

**Applications Software Version:** 1.07

**Firmware Revision:** N/A

**BACnet Protocol Revision:** 4

**Product Description:** VorTek multivariable flow-meter

**BACnet Standardized Device Profile (Annex L):**

- BACnet Operator Workstation (B-OWS)
- BACnet Advanced Operator Workstation (B-AWS)
- BACnet Operator Display (B-OD)
- BACnet Building Controller (B-BC)
- BACnet Advanced Application Controller (B-AAC)
- BACnet Application Specific Controller (B-ASC)
- BACnet Smart Sensor (B-SS)
- BACnet Smart Actuator (B-SA)

**List all BACnet Interoperability Building Blocks Supported (Annex K):**

BIBBs
DS-RP-B
DS-WP-B
DM-DDB-B
DM-DOB-B
DM-DCC-B
DS-RPM-B
DS-WPM-B

<b>Services Supported</b>	
Read Property	Execute
Write Property	Execute
Read Property Multiple	Execute
Write Property Multiple	Execute
Who-Is	Execute
I-Am	Initiate
Who-Has	Execute
I-Have	Initiate
Device Communication Control	Execute

**Segmentation Capability:**

- Able to transmit segmented messages
- Able to receive segmented messages

Window Size

Window Size

**Standard Object Types Supported:**

<b>Standard Object Types Supported</b>				
<b>Object Type</b>	<b>Dynamically Creatable</b>	<b>Dynamically Delete-able</b>	<b>Additional Writable Properties</b>	<b>Range Restrictions</b>
Analog Input (AI)	No	No	None	None
Binary Input (BV)	No	No	None	None
Binary Value	No	No	None	None
Device	No	No	None	None

<b>Standard Object Types Supported Writable Properties</b>			
<b>Object Type</b>	<b>Properties</b>		
Analog Input (AI)	Present Value	Out-Of-Service	
Binary Input (BV)	Present Value	Out-Of-Service	Polarity
Binary Value	Present Value	Out-Of-Service	
Device			

**Object List:**

Properties of Analog Input/Value Objects Type						
ID	Name	Present Value	Status Flags	Event State	Out of Service	Units
AI1	Volume Flow	?	F,F,F,F	Normal	False	?
AI2	Mass Flow	?	F,F,F,F	Normal	False	?
AI3	Temperature 1	?	F,F,F,F	Normal	False	?
AI4	Temperature 2	?	F,F,F,F	Normal	False	?
AI5	Pressure	?	F,F,F,F	Normal	False	?
AI6	Density	?	F,F,F,F	Normal	False	?
AI7	Energy Flow	?	F,F,F,F	Normal	False	?
AI8	Totalizer 1	?	F,F,F,F	Normal	False	?
AI9	Totalizer 2	?	F,F,F,F	Normal	False	?
AI10	StatusRegister	?	F,F,F,F	Normal	False	?
AI11	Channel 1 (4-20mA)	?	F,F,F,F	Normal	False	?
AI12	Channel 2 (4-20mA)	?	F,F,F,F	Normal	False	?
AI13	Channel 3 (4-20mA)	?	F,F,F,F	Normal	False	?
AI14	Scaled Freq	?	F,F,F,F	Normal	False	?
AI15	Flow Velocity	?	F,F,F,F	Normal	False	?
AI16	Viscosity	?	F,F,F,F	Normal	False	?
AI17	Frequency	?	F,F,F,F	Normal	False	?
AI18	Turbine Amp	?	F,F,F,F	Normal	False	?
AI19	FilterSetting	?	F,F,F,F	Normal	False	?

Properties of Analog Input/Value Objects Type						
ID	Name	Present Value	Status Flags	Event State	Out of Service	Polarity
BI1	Alarm1	?	F,F,F,F	Normal	False	Normal
BI2	Alarm2	?	F,F,F,F	Normal	False	Normal
BI3	Alarm3	?	F,F,F,F	Normal	False	Normal
BI4	External	?	F,F,F,F	Normal	False	Normal



Properties of Analog Input/Value Objects Type						
ID	Name	Present Value	Status Flags	Event State	Out of Service	out-of-service
BV1	Reset	?	F,F,F,F	Normal	False	False

### Data Link Layer Options:

- BACnet IP, (Annex J)
- BACnet IP, (Annex J), Foreign Device
- ISO 8802-3, Ethernet (Clause 7)
- ANSI/ATA 878.1, 2.5 Mb. ARCNET (Clause 8)
- ANSI/ATA 878.1, EIA-485 ARCNET (Clause 8), baud rate(s)
- MS/TP master (Clause 9), baud rate(s): 9600, 19200, 38400
- MS/TP slave (Clause 9), baud rate(s):
- Point-To-Point, EIA 232 (Clause 10), baud rate(s):
- Point-To-Point, modem, (Clause 10), baud rate(s):
- LonTalk, (Clause 11), medium:
- Other:

### Device Address Binding:

Is static device binding supported? (This is currently necessary for two-way communication with MS/TP slaves and certain other devices.) :

Yes                       No

### Networking Options:

- Router, Clause 6 - List all routing configurations, e.g., ARCNET-Ethernet, Ethernet-MS/TP, etc.
- Annex H, BACnet Tunneling Router over IP
- BACnet/IP Broadcast Management Device (BBMD)
  - Does the BBMD support registrations by Foreign Devices?
    - Yes    No
  - Does the BBMD support network address translation?
    - Yes    No

### Network Security Options:

- Non-secure Device - is capable of operating without BACnet Network Security
- Secure Device - is capable of using BACnet Network Security (NS-SD BVBB)

- Multiple Application-Specific Keys:
- Supports encryption (NS-ED BVBB)
- Key Server (NS-KS BVBB)

**Character Sets Supported:**

Indicating support for multiple character sets does not imply that they can all be supported simultaneously.

- |   |  |
|---|--|
| <input checked="" type="checkbox"/> ANSI X3.4 | <input type="checkbox"/> IBM™/Microsoft™DBCS |
| <input type="checkbox"/> ISO 8859-1           | <input type="checkbox"/> ISO 10646 (UCS-2)   |
| <input type="checkbox"/> ISO 10646 (UCS-4)    | <input type="checkbox"/> JIS C 6226          |

**If this product is a communication gateway, describe the types of non-BACnet equipment/networks(s) that the gateway supports:**

- N/A

## 5. Acronyms and Definitions

<b>Item</b>	<b>Description</b>
APDU	Application Protocol Data Unit
BACnet	Building Automation and Control Network- Data communication protocol
MS/TP	Master-Slave Token passing(a twisted pair RS485 network created by BACnet)
BIBB	BACnet Interoperability Building Block (Specific individual function blocks for data exchange between interoperable devices).
BV	Binary Value
BI	Binary Input
AI	Analog Input
RP	Read Property
WP	Write Property
RPM	Read Property Multiple
WPM	Write Property Multiple.
DDB	Dynamic Device Binding
DOB	Dynamic Object Binding
DCC	Device communication Control

## Chapter 5 Troubleshooting and Repair



### Warning!

Before attempting any flow meter repair, verify that the line is not pressurized. Always remove main power before disassembling any part of the mass flow meter.

### Hidden Diagnostics Menus

The menus shown on the following page can be accessed using the password 16363, then moving to the display that reads “Diagnostics Menu” and pressing ENTER (rather than one of the arrow keys).

Use the right arrow key to move to the second column. Press EXIT to move from the second column back to the first, press EXIT while in the first column to return to the setup menus.

**Caution:** password 16363 will allow full access to the configuration and should be used carefully to avoid changes that can adversely alter the function of the meter.

Each of the menus on the following page will first be defined followed by specific troubleshooting steps.

## Hidden Diagnostics Menus

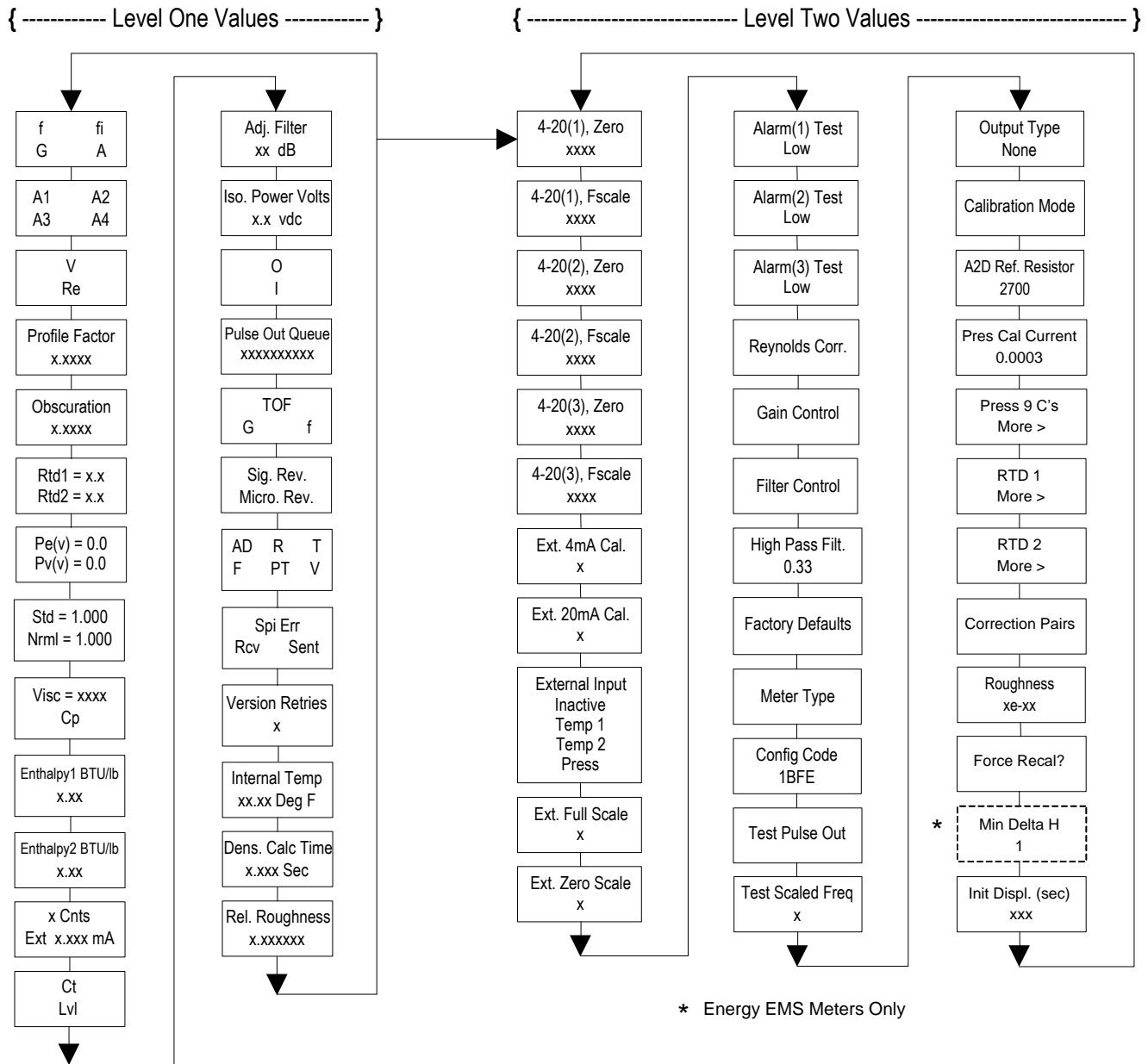

## Level One Hidden Diagnostics Values

- **f** = Turbine frequency (Hz).
- **fi** = Adaptive filter – should be approximately 25% higher than the turbine frequency, this is a low-pass filter. If the meter is using the Filter Control (see below) in the manual mode, **fi** will be displayed as **fm**.
- **G** = Gain (applied to turbine signal amplitude). Gain defaults to 1.0 and can be changed using the Gain Control (see below).
- **A** = Amplitude of turbine signal in Volts rms.
- **A1, A2, A3, A4** = A/D counts representing the turbine signal amplitude. Each stage (A1-A4) cannot exceed 512. Beginning with stage A1, the A/D counts increase as the flow increases. When stage A1 reaches 512, it will shift to stage A2. This will continue as the flow rate increases until all 4 stages read 512 at high flow rates. Higher flow rates (stronger signal strength) will result in more stages reading 512.
- **V** = Calculated average pipe velocity (ft/sec).
- **Re** = Calculated Reynolds number.
- **Profile Factor** = Factory use only.
- **Obscuration Factor** = Factory use only.
- **RTD1** = Resistance value of integral RTD in ohms.
- **RTD2** = Optional RTD resistance value in ohms.
- **Pe(v)** = Pressure transducer excitation voltage
- **Pv(v)** = Pressure transducer sense voltage.
- **Stnd** = Density of fluid at standard conditions.
- **Nrml** = Density of fluid at normal conditions.
- **Viscosity** = Calculated viscosity of flowing fluid.
- **Enthalpy1 BTU/lb** = Factory use only.
- **Enthalpy2 BTU/lb** = Factory use only.
- **x Cnts** = A/D counts from the external 4-20 mA input.
- **Ext x.xxx mA** = Calculated external 4-20 mA input from the digital counts.
- **Ck** = Calculated Ck at current operating conditions. Ck is a variable in the equation that relates signal strength, density, and velocity for a given application. It is used for noise rejection purposes. Ck directly controls the fi value (see above). If the Ck is set too low (in the calibration menu), then the fi value will be too low and the turbine signal will be rejected resulting in zero flow rate being displayed. The calculated Ck value in this menu can be compared to the actual Ck setting in the calibration menu to help determine if the Ck setting is correct.

- **Lvl** = Threshold level. If the Low Flow Cutoff in the calibration menu is set above this value, the meter will read zero flow. The Lvl level can be checked at no flow. At no flow, the Lvl must be below the Low Flow Cutoff setting or the meter will have an output at no flow.
- **Adj. Filter** = Adjustable filter. Displays the filtering in decibels. Normally reads zero. If this value is consistently -5 or -10, for example, the Ck or density setting may be wrong.
- **Iso. Power Volts** = Nominally 2.7 VDC, if less than this check the flow meter input power.
- **O,I** = Factory use only.
- **Pulse Out Queue** = Pulse output queue. This value will accumulate if the totalizer is accumulating faster than the pulse output hardware can function. The queue will allow the pulses to “catch up” later if the flow rate decreases. A better practice is to slow down the totalizer pulse by increasing the value in the (unit)/pulse setting in the totalizer menu.
- **TOF, G, f** = Factory use only.
- **Sig. Rev** = Signal board hardware and firmware revision.
- **Miro Rev** = Microprocessor board hardware and firmware revision.
- **AD, R, T, F, PT, V** = Factory use only.
- **SPI Err, Rcv, Sent** = Factory use only.
- **Version Retries** = Factory use only.
- **Internal Temperature** = Electronics temperature.
- **Dens. Calc Time** = Factory use only.
- **Rel. Roughness** = Factory use only.

## Level Two Hidden Diagnostics Values

- **4-20(1) Zero** = Analog counts to calibrate zero on analog output 1.
- **4-20(1) FScale** = Analog counts to cal. full scale on analog output 1.
- **4-20(2) Zero** = Analog counts to calibrate zero on analog output 2.
- **4-20(2) FScale** = Analog counts to cal. full scale on analog output 2.
- **4-20(3) Zero** = Analog counts to calibrate zero on analog output 3.

- **4-20(3) FScale** = Analog counts to cal. full scale on analog output 3.
- **Ext. 4 mA Cal.** = Enter 0 for auto calibration or enter factory supplied A/D counts. Note: You must connect a known 4.00 mA input if you are going to calibrate the unit.
- **Ext. 20 mA Cal.** = Enter 0 for auto calibration or enter factory supplied A/D counts. Note: You must connect a known 20.00 mA input if you are going to calibrate the unit.
- **External Input** = Enter what the external 4-20 mA input represents, i.e. Temperature 1, Temperature 2, or Pressure. The meter will use this for its internal calculations.
- **Ext. Full Scale** = Enter the full scale units that correlate to the 20 mA point. Note: It must be in the units for the selected input type such as Deg F, Deg C, PSIA, Bar A, etc.
- **Ext. Zero Scale** = Same as above but for the 4 mA point.
- **Alarm (1) Test** = Used as a test to verify that the alarm circuit is functioning. When low is selected the alarm will initiate a low alarm on the output. When High is selected it will give a high alarm on the output.
- **Alarm (2) Test** = Used as a test to verify that the alarm circuit is functioning. When low is selected the alarm will initiate a low alarm on the output. When High is selected it will give a high alarm on the output.
- **Alarm (3) Test** = Used as a test to verify that the alarm circuit is functioning. When low is selected the alarm will initiate a low alarm on the output. When High is selected it will give a high alarm on the output.
- **Reynolds Corr.** = Reynolds number correction for the flow profile.
- **Gain Control** = Manual gain control (factory use only). Leave set at 1.
- **Filter control** = Manual filter control. This value can be changed to any number to force the fi value to a constant. A value of zero activates the automatic filter control which sets fi at a level that floats above the f value.
- **High Pass Filter** = Filter setting – Factory use only
- **Factory Defaults** = Reset factory defaults. If you change this to Yes and press Enter, all the factory configuration is lost and you must reconfigure the entire program. Consult the factory before performing this process, it is required only in very rare cases.
- **Config Code** = Factory use only.



- **Test Pulse Out** = Force totalizer pulse. Set to Yes and press enter to send one pulse. Very useful to test totalizer counting equipment.
- **Test Scaled Freq** = Enter a frequency value in order to test the scaled frequency output. Return to 0 to stop the test.
- **Output Type** = Factory use only.
- **Calibration Mode** = Factory use only.
- **A2D Ref. Resistor** = Factory use only.
- **Pressure Cal Current** = Calibration value for the electronics and pressure transducer combination. Consult Factory for value.
- **Pressure 9Cs** = Nine pressure coefficients unique to the pressure transducer. Use the RIGHT ARROW to access all nine coefficients.
  - **Press. Max psi** = Based on installed sensor.
  - **Press. Min psi** = 0 psia
- **RTD1.** Press the RIGHT ARROW to access:
  - **Ro** = RTD resistance at 0°C (1000 ohms).
  - **A** = RTD coefficient A (.0039083).
  - **B** = RTD coefficient B (-5.775e-07).
  - **RTD1 Max Deg. F** = 500
  - **RTD1 Min Deg. F** = -330
- **RTD2** = Second RTD configuration, for special applications only.
- **Correction Pairs**
  - **ft3/sec** (1 through 10)
  - **%Dev.** (1 through 10)
- **Roughness** = Factory use only.
- **Force Recal?** = Factory use only.
- **Min. Delta H** – Energy EMS meters only. Sets the deadband for totalization to begin. Must be greater than this number (1 default) to initiate the totalizer.
- **Init Displ. (sec)** = Enter a value in seconds to initialize the display every xxx seconds. Enter a value of 0 to disable initializing the display.

## Analog Output Calibration

To check the 4–20 mA circuit, connect a DVM in series with the output loop. Select zero or full scale (from the second column of the hidden diagnostics) and then actuate the enter key twice. This action will cause the meter to output its 4 mA or 20 mA conditions. If the DVM indicates a current greater than  $\pm 0.006$  mA from 4 or 20, adjust the setting up or down until the output is calibrated.

Note: these settings are not for adjusting the output zero and span to match a flow range, that function is located in the Output Menu.

## Display Contrast Adjustment

- 1) Hold down the “Exit” button on the front panel for 5 to 10 seconds. “Setting Contrast” will appear.
- 2) Push the “Up” arrow to darken the display or the “Down” arrow to lighten it.
- 3) Push the “Enter” button to save the contrast setting.

## Troubleshooting the Flow Meter



### Warning!

Before attempting any flow meter repair, verify that the line is not pressurized. Always remove main power before disassembling any part of the mass flow meter. Use hazardous area precautions if applicable. Static sensitive electronics - use electro-static discharge precautions.

### First Check Items:

- Installation Direction Correct
- Installation Depth Correct (Insertion style meter)
- Power and Wiring Correct
- Application Fluid Correct

**Please record what the fluid is** \_\_\_\_\_

- Meter Range Correct for the Application
- Meter Configuration Correct
- Describe Installation Geometry i.e. upstream diameters, valve position, downstream diameters, etc.

### Record Values:

**Record the following values from the Run Menu with the meter installed in order to determine the operating state of the flow meter:**

	With Flow	With No Flow (if possible)
Flow =		
Temperature =		
Pressure =		
Density =		
Error Messages? =		

**Record the following values from the Hidden Diagnostics Menu with the meter installed:** (Use password 16363 to access.)

	With Flow	With No Flow (if possible)
f =		
fi =		
A =		
A1 =		
A2 =		
A3 =		
A4 =		
V =		

**Record values - Hidden Diagnostics Menu continued:**

	<b>With Flow</b>	<b>With No Flow (if possible)</b>
Ct =		
Lvl =		
Adj. Filter =		
Iso. Power Volts =		

**Record the following values from the Calibration Menu.**

Pipe ID =	
Meter Factor =	
Abs. Roughness in. =	
Turbine Coef Ct =	
Low Flow Cutoff =	
Serial Number =	

**Determine the Fault****Symptom: Output at no Flow**

1. The low flow cutoff is set too low. At no flow, go to the first column of the hidden diagnostics menu and record the Lvl value. The low flow cutoff must be set above this value.
2. Example: at no flow, Lvl = 25. Set the low flow cutoff in the Calibration Menu to approximately 28 and the meter will no longer read a flow rate at no flow.

**Symptom: Erratic Output**

1. The flow rate may be too low, just at the cutoff of the meter range, and the flow cycles above and below the cutoff making an erratic output. Consult the factory if necessary to confirm the meter range based on current operating conditions. It may be possible to lower the low flow cutoff to increase the meter range. See the example above for output at no flow, only this time the low flow cutoff is set too high. You can lower this value to increase the meter range as long as you do not create the output at no flow condition previously described.
2. Mechanical installation may be incorrect. Verify the straight run is adequate as described in Chapter 2. Verify the insertion depth and flow direction.
3. The meter may be reacting to actual changes in the flow stream. The output can be smoothed using a time constant.

The displayed values can be smoothed using the time constant in the Display Menu. The analog outputs can be smoothed using the time constant in the Output Menu. A time constant of 1 will result in the change in value reaching 63% of its final value in one second. A time constant of 4 is 22%, 10 is 9.5% and 50 is 1.9% of the final value in one second. The time constant equation is shown below (TC = Time Constant).

$$\begin{array}{l} \text{\% change to final value} \\ \text{in one second} \end{array} = 100 (1 - e^{(-1/TC)})$$

4. The coefficient Ck may be incorrectly set. The Ck is a value in the equation used to determine if a frequency represents a valid turbine signal given the fluid density and signal amplitude. In practice, the Ck value controls the adaptive filter, fi, setting. During flow, view the f and fi values in the first column of the hidden diagnostics. The fi value should be approximately 10-20 % higher than the f value. If you raise the Ck setting in the Calibration Menu, then the fi value will increase. The fi is a low pass filter, so by increasing it or lowering it, you can alter the range of frequencies that the meter will accept. If the turbine signal is strong, the fi value will increase to a large number – this is correct.

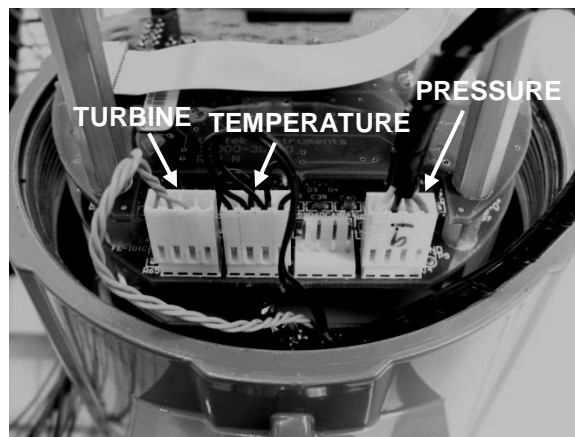

Figure 5-1. Electronics Stack Sensor Connections

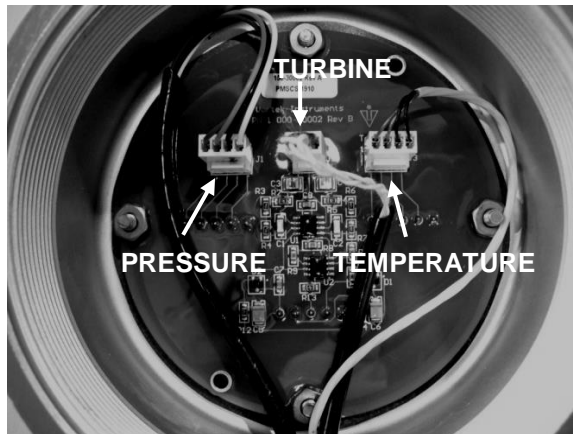

Figure 5-2. Remote Feed Through Board Sensor Connections

### Symptom: No Output

1. For remote mounted electronics, carefully check all the wiring connections in the remote mount junction box. There are 18 connections that must be correct, verify each color (black and red), shield, and wire number.
2. Turn on the pressure and temperature display in the Display Menu and verify that the pressure and temperature are correct.
3. Using ESD precautions and hazardous area precautions, remove the electronics enclosure window cover. Disconnect the turbine sensor from the electronics stack or remote feed through board. Refer to Figure 5-1 or 5-2. Measure the resistance between the outside pins – the resistance should be around 100 ohms. Measure the resistance from the center pin to the meter ground – the resistance should be less than 1 ohm.

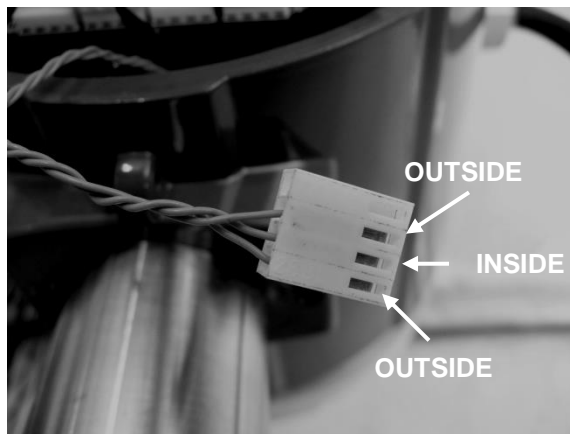

Figure 5-3. Turbine Sensor Connector

With the sensor still disconnected, go to the first column of the hidden diagnostics and display the turbine frequency, f. Hold a

finger on the three exposed pins on the analog board. The meter should read electrical noise, 60 Hz for example. If all readings are correct, re-install turbine sensor wires.

4. Verify all meter configuration and troubleshooting steps previously described. There are many possible causes of this problem, consult factory if necessary.

#### **Symptom: Meter Displays Temperature Fault**

1. For remote mounted electronics, carefully check all the wiring connections in the remote mount junction box. There are 18 connections that must be correct, verify each color (black and red), shield, and wire number.
2. Go to the first column of the hidden diagnostics and check the resistance of the rtd1. It should be about 1080 ohms at room temperature.
3. Using ESD precautions and hazardous area precautions, remove the electronics enclosure window cover. Disconnect the temperature sensor from the electronics stack or the remote feed through board. Refer to Figure 5-1, 5-2 and 5-4. Measure the resistance across the outside pins of the temperature sensor connector. It should read approximately 1080 ohms at room temperature (higher resistance at higher temperatures). Measure the resistance across the inside pins, they should read the same.
4. Measure the resistance from one of the outside pins to case ground then from one of the inside pins to case ground. They should read open.

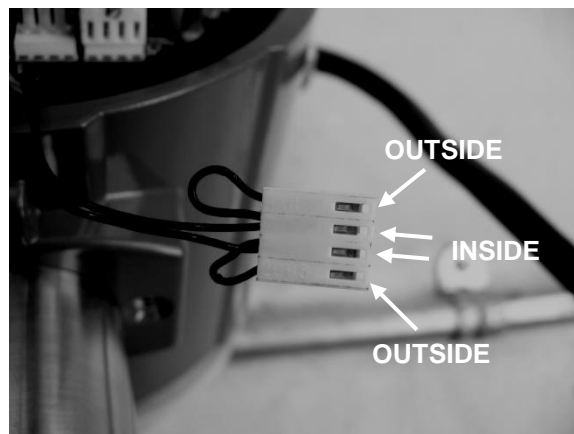

Figure 5-4. Temperature Sensor Connector

5. Consult factory with findings

**Symptom: Meter Displays Pressure Fault**

1. For remote mounted electronics, carefully check all the wiring connections in the remote mount junction box. There are 18 connections that must be correct, verify each color (black and red), shield, and wire number.
2. Using ESD precautions and hazardous area precautions, remove the electronics enclosure window cover. Disconnect the pressure sensor from the electronics stack or the remote feed through board. Measure the resistance across the outside pins of the pressure sensor connector, then across the inside pins. Both readings should be approximately 4400 ohms.

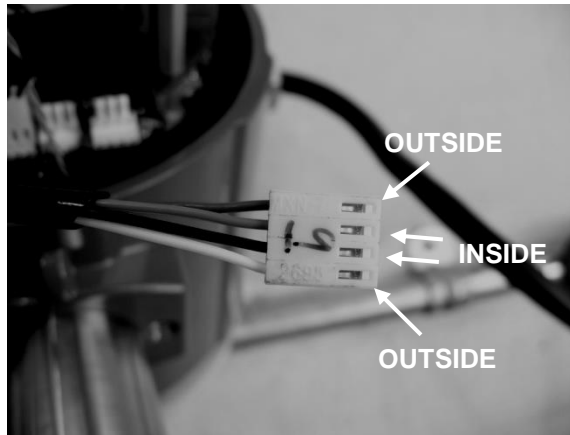

Figure 5-5. Pressure Sensor Connector

3. Measure the resistance from one of the outside pins to case ground then from one of the inside pins to case ground. They should read open.
4. Go to the first column of the hidden diagnostics and record the Pe(V) and Pv(V) values and consult the factory with findings.



## Electronics Assembly Replacement (All Meters)

The electronics boards are electrostatically sensitive. Wear a grounding wrist strap and make sure to observe proper handling precautions required for static-sensitive components.



### Warning!

Before attempting any flow meter repair, verify that the line is not pressurized.

Always remove main power before disassembling any part of the mass flow meter.

1. Turn off power to the unit.
2. Locate and loosen the small set screw which locks the larger enclosure cover in place. Unscrew the cover to expose the electronics stack.
3. Locate the sensor harnesses which come up from the neck of the flow meter and attaches to the circuit boards. Make note of the location of each sensor connection. Refer to figures 5-1 and 5-2. The turbine sensor connection is on the left, the temperature sensor connection (if present) is second from the left, and the pressure sensor connection (if present) is the right most connector. Use small pliers to pull the sensor wiring connectors off of the circuit boards.
4. Locate and loosen the small set screw which locks the smaller enclosure cover in place. Unscrew the cover to expose the field wiring strip. Tag and remove the field wires.
5. Remove the screws that hold the black wiring label in place, remove the label.
6. Locate the 4 Phillips head screws which are spaced at 90-degrees around the terminal board. These screws hold the electronics stack in the enclosure. Loosen these screws (Note: that these are captive screws, they will stay inside the enclosure).
7. Carefully remove the electronics stack from the opposite side of the enclosure. If the electronics stack will not come out, gently tap the terminal strip with the screw driver handle. This will loosen the rubber sealing gasket on the other side of the enclosure wall. Be careful that the stack does not hang up on the loose sensor harnesses.
8. Repeat steps 1 through 6 in reverse order to install the new electronics stack.

## Returning Equipment to the Factory

**Before returning any Pro-T™ flow meter to the factory, you must request a Return Material Authorization (RMA) number.**

To obtain an RMA number and the correct shipping address, contact Customer Service at:

888-386-7835 or 303-682-9999 in the USA,

When contacting Customer Service, be sure to have the meter serial number and model code.

Please see the Meter Troubleshooting Checklist for additional items which may help with problem isolation. When requesting further troubleshooting guidance, please record the values on the checklist at no flow and during flow if possible.



## Appendix A Product Specifications

### Accuracy

Process Variables	Pro-T™ Insertion Meters <sup>(1)</sup>
	Liquid, Gas & Steam
Mass Flow Rate	±2% of rate <sup>(2)</sup> over a 30:1 range <sup>(3)</sup>
Volumetric Flow Rate	±1.5% of rate over a 30:1 range <sup>(3)</sup>
Temperature	± 2° F (± 1° C)
Pressure	0.3% of transducer full scale
Density	0.5% of reading <sup>(2)</sup>

- Notes: (1) Accuracies stated are for the total mass flow through the pipe.  
 (2) Over 50 to 100% of the pressure transducer's full scale.  
 (3) Nominal rangeability is stated. Precise rangeability depends on fluid and pipe size.

Repeatability	Mass Flow Rate: 0.2% of rate. Volumetric Flow Rate: 0.1% of rate. Temperature: ± 0.2° F (± 0.1° C). Pressure: 0.05% of full scale. Density: 0.1% of reading.
Stability Over 12 Months	Mass Flow Rate: 0.2% of rate maximum. Volumetric Flow Rate: Negligible error. Temperature: ± 0.1° F (± 0.5° C) maximum. Pressure: 0.1% of full scale maximum. Density: 0.1% of reading maximum.
Response Time	Adjustable from 1 to 100 seconds.
Material Capability	Any gas, liquid or steam compatible with 316L stainless steel. Not recommended for multi-phase fluids.
Flow Rates	Typical mass flow ranges are given in the following tables. Precise flow depends on the fluid and pipe size. Consult factory for sizing program.

Typical Air Minimum and Maximum Flow Rates (SCFM)						
Air at 70°F						
Pressure	Nominal Pipe Size (in)					
Rotor - R40	3	6	8	12	16	24
0 psig	7	31	55	129	213	529
	98	404	714	1660	2729	6702
100 psig	62	255	451	1051	1730	4257
	790	3252	5741	13313	21791	53019
200 psig	117	484	857	1992	3273	8031
	1494	6146	10846	25128	41083	99739
Rotor - R30						
0 psig	9	36	63	148	244	606
	143	590	1043	2426	3984	9765
100 psig	71	292	517	1204	1980	4871
	1153	4746	8376	19412	31753	77152
200 psig	134	555	981	2281	3747	9186
	2181	8964	15814	36617	59832	145094
Rotor - R20						
0 psig	15	63	112	262	432	1071
	230	951	1680	3904	6406	15665
100 psig	125	517	913	2124	3489	8557
	1855	7628	13458	31168	50942	123591
200 psig	237	979	1730	4020	6595	16126
	3506	14397	25389	58747	95927	232348
Rotor - R10						
0 psig	26	110	195	454	748	1849
	478	1968	3476	8067	13217	32219
100 psig	216	893	1578	3666	6016	14715
	3831	15728	27734	64166	104762	253698
200 psig	410	1691	2987	6933	11362	27714
	7230	29650	52259	120804	197092	476732

\* Rotors R25 and R15 are also available.

Typical Air Minimum and Maximum Flow Rates (nm <sup>3</sup> /hr)						
Air at 20°C						
Pressure	Nominal Pipe Size (mm)					
Rotor - R40	80	150	200	300	400	600
0 barg	12	49	87	204	337	838
	154	639	1130	2628	4320	10607
5 barg	74	305	540	1259	2072	5107
	946	3898	6884	15969	26152	63694
10 barg	137	567	1002	2332	3835	9423
	1751	7205	12718	29476	48216	117169
Rotor - R30						
0 barg	14	56	100	234	386	960
	226	934	1651	3839	6306	15455
5 barg	84	350	619	1441	2373	5844
	1382	5690	10046	23290	38115	92698
10 barg	157	649	1148	2671	4390	10779
	2556	10511	18548	42965	70237	170473
Rotor - R20						
0 barg	24	100	178	415	684	1696
	365	1505	2660	6179	10139	24794
5 barg	150	618	1094	2544	4182	10271
	2224	9149	16145	37407	61166	148520
10 barg	278	1146	2026	4709	7731	18929
	4110	16888	29789	68956	112643	273032
Rotor - R10						
0 barg	42	174	308	718	1184	2927
	756	3115	5502	12768	20919	50995
5 barg	259	1069	1890	4393	7214	17668
	4595	18874	33290	77048	125842	304938
10 barg	480	1980	3499	8125	13323	32541
	8481	34799	61349	141871	231535	560318

\* Rotors R25 and R15 are also available.

Typical Saturated Steam Minimum and Maximum						
Flow Rates (lb/hr)						
Pressure	Nominal Pipe Size (in)					
Rotor - R40	3	6	8	12	16	24
5 psig	22	91	162	378	625	1555
	287	1187	2098	4883	8029	19727
100 psig	119	496	878	2046	3371	8328
	1540	6350	11216	26034	42668	104092
200 psig	220	913	1615	3761	6191	15249
	2827	11643	20558	47681	78064	190027
Rotor - R30						
5 psig	25	105	186	434	717	1782
	420	1735	3068	7135	11721	28745
100 psig	137	568	1006	2344	3861	9530
	2251	9272	16373	37984	62207	151526
200 psig	253	1046	1850	4308	7088	17446
	4129	16994	29996	69532	113761	276542
Rotor - R20						
5 psig	45	186	330	770	1270	3150
	677	2797	4943	11485	18849	46119
100 psig	243	1005	1778	4140	6811	16762
	3623	14915	26328	61035	99870	242834
200 psig	447	1848	3268	7601	12492	30657
	6643	27317	48203	111658	182535	443035
Rotor - R10						
5 psig	78	323	572	1334	2199	5440
	1405	5790	10227	23736	38897	94870
100 psig	421	1739	3075	7153	11755	28849
	7490	30791	54325	125807	205605	498759
200 psig	774	3195	5647	13123	21541	52728
	13719	56341	99362	229926	375467	909528

\* Rotors R25 and R15 are also available.

Typical Saturated Steam Minimum and Maximum						
Flow Rates (kg/hr)						
Pressure	Nominal Pipe Size (mm)					
Rotor - R40	80	150	200	300	400	600
1.4 barg	17	72	127	297	491	1219
	225	929	1642	3817	6270	15367
5 barg	42	173	306	713	1176	2907
	537	2216	3915	9090	14905	36400
10 barg	75	310	549	1279	2106	5194
	962	3963	6999	16239	26600	64815
Rotor - R30						
1.4 barg	20	82	146	341	563	1396
	329	1358	2399	5575	9149	22384
5 barg	48	198	350	817	1347	3328
	785	3237	5716	13265	21735	52993
10 barg	86	355	629	1465	2411	5943
	1405	5786	10215	23687	38771	94337
Rotor - R20						
1.4 barg	35	146	259	604	995	2463
	530	2187	3863	8968	14704	35898
5 barg	85	350	620	1444	2377	5856
	1265	5207	9194	21322	34903	84940
10 barg	152	628	1111	2586	4252	10448
	2261	9303	16419	38049	62227	151156
Rotor - R10						
1.4 barg	61	253	448	1045	1721	4247
	1098	4522	7985	18520	30320	73805
5 barg	147	606	1072	2496	4103	10082
	2615	10755	18979	43967	71883	174497
10 barg	263	1087	1921	4466	7335	17975
	4672	19197	33862	78386	128050	310382

\* Rotors R25 and R15 are also available.



## Linear Range

Fluid: Gas or Steam				
	Minimum Velocity		Maximum Velocity	
	(ft/sec)	(m/sec)	(ft/sec)	(m/sec)
<b>R40</b>	3.5	1.07	43.0	13.11
<b>R30</b>	4.0	1.22	62.5	19.05
<b>R25</b>	5.0	1.52	80.0	24.38
<b>R20</b>	7.0	2.13	100.0	30.48
<b>R15</b>	8.5	2.59	134.6	41.03
<b>R10</b>	12.0	3.66	205.0	62.48

Min flow rates change is not reflected in the above  
Process Fluid Pressure

Pro-T™ Pressure Ratings				
Probe Seal	Process Connection	Material	Rating	Ordering Code
Compression Fitting	2-inch MNPT	316L SS	ANSI 600 lb	CNPT
	2-inch 150 lb flange, DN50 PN16, JIS 10K	316L SS	ANSI 150 lb, PN16 JIS 10K	C150, C16, CJ10
	2-inch 300 lb flange, DN50 PN40, JIS 20K	316L SS	ANSI 300 lb, PN40 JIS 20K	C300, C40, CJ20
	2-inch 600 lb flange, DN50 PN63, JIS 30K	316L SS	ANSI 600 lb, PN63 JIS 30K	C600, C63, CJ30
	2-inch 900 lb flange	316L SS	ANSI 900 lb	C900
Packing Gland	2-inch MNPT	316L SS	50 psig	PNPT
	2-inch 150 lb flange, DN50 PN16, JIS 10K	316L SS	50 psig	P150, P16, PJ10
	2-inch 300 lb flange, DN50 PN40, JIS 20K	316L SS	50 psig	P300, P40, PJ20
Packing Gland with Removable Retractor	2-inch MNPT	316L SS	ANSI 300 lb	PM, RR
	2-inch 150 lb flange, DN50 PN16, JIS 10K	316L SS	ANSI 150 lb	P150, P16, PJ10,RR
	2-inch 300 lb flange, DN50 PN40, JIS 20K	316L SS	ANSI 300 lb	P300, P40, PJ20,RR

Packing Gland with Permanent Retractor	2-inch MNPT	316L SS	ANSI 600 lb	PNPTR
	2-inch 150 lb flange, DN50 PN16, JIS 10K	316L SS	ANSI 150 lb	P150R, P16R, PJ10R
	2-inch 300 lb flange, DN50, PN40, JIS 20K	316L SS	ANSI 300 lb	P300R, P40R, PJ20R
	2-inch 600 lb flange, DN50 PN63, JIS 30K	316L SS	ANSI 600 lb	P600R, P63R, PJ30R
	2-inch 900 lb flange	316L SS	ANSI 900 lb	P900R

Pressure Transducer Ranges

Pressure Sensor Ranges <sup>(1)</sup> , psia (bara)			
Full Scale Operating Pressure		Maximum Over-Range Pressure	
psia	(bara)	psia	(bara)
30	2	60	4
100	7	200	14
300	20	600	40
500	35	1000	70
1500	100	2500	175

Note: (1) To maximize accuracy, specify the lowest full scale operating pressure range for the application. To avoid damage, the flow meter must never be subjected to pressure above the over-range pressure shown above.

**Power Requirements** 12 to 36 VDC, 25 mA, 1 W max., Loop Powered Volumetric or Mass  
 12 to 36 VDC, 300 mA, 9 W max. Multiparameter Mass options  
 100 to 240 VAC, 50/60 Hz, 5 W max. Multiparameter Mass options

Use a Class 2 isolated power supply that is grounded, provides DC output, and has no more than 10% output ripple.

Installation (Over-voltage) Category II for transient over-voltages

AC & DC Mains supply voltage fluctuations are not to exceed +/-10% of the rated supply voltage range.

User is responsible for the provision of an external disconnect means, disconnect line 1 and line 2 when 220 / 240 VAC power is used, also provide over-current protection for the equipment (both AC and DC models).

**Display** Alphanumeric 2 x 16 LCD digital display.  
 Six push-button switches (up, down, right, left, enter, exit) operable through explosion-proof window using hand-held magnet. Viewing at 90-degree mounting intervals.

**Process Fluid and Ambient Temperature** Process Fluid:  
 Standard temperature sensor: -67 to 450 °F (-55 to 232 °C)  
 High temperature sensor: -448° to 850°F (-267° to 454°C)

Ambient:  
 Operating temperature range: -40 to 140° F (-40 to 60° C)  
 Storage temperature range: -40 to 185° F (-40 to 85° C)  
 Maximum relative humidity: 0-98%, non-condensing conditions  
 Maximum altitude: -2000 to 14,000 feet (-610 to 4268 meters)

Pollution Degree 2 for the ambient environment

Output Signals <sup>(1)</sup>	<p>Analog: Volumetric Meter: field rangeable linear 4-20 mA output signal (1200 Ohms maximum loop resistance) selected by user for mass flow rate or volumetric flow rate.</p> <p>Communications: HART, MODBUS, RS485, BACNet</p> <p>Multiparameter Meter: up to three field rangeable linear 4-20 mA output signals (1200 Ohms maximum loop resistance) selected from the five parameters—mass flow rate, volumetric flow rate, temperature, pressure and density.</p> <p>Pulse: Pulse output for totalization is a 50-millisecond duration pulse operating a solid-state relay capable of switching 40 VDC, 40 mA maximum.</p> <p>Note: (1) All outputs are optically isolated and require external power for operation.</p>
Alarms	Up to three programmable solid-state relays for high, low or window alarms capable of switching 40 VDC, 40 mA maximum.
Totalizer	Based on user-determined flow units, six significant figures in scientific notation. Total stored in non-volatile memory.
Wetted Materials	<p>316L stainless steel.</p> <p>302 stainless steel.</p> <p>17-4 PH stainless steel.</p> <p>Tungsten carbide.</p> <p>Sapphire</p> <p>Teflon® packing gland below 500° F (260° C).</p> <p>Graphite packing gland above 500° F (260° C).</p>
Enclosure Protection Classification	NEMA 4X and IP66 cast enclosure.
Electrical Ports	Two 3/4-inch female NPT ports.
Mounting Connections	<p>Series M23 Permanent installation: 2-inch MNPT; 150, 300, 600, 900 lb ANSI flange, PN16, PN40, PN63 flange, JIS 10K, 20K, 30K flange with compression fitting probe seal.</p> <p>Series M23 Hot Tap<sup>(1)</sup> Installation: 2-inch MNPT; 150, 300, 600, 900 lb ANSI flange, PN16, PN40, PN63 flange, JIS 10K, 20K, 30K flange and optional retractor with packing gland probe seal.</p> <p>Note: (1) Removable under line pressure.</p>
Mounting Position	Meter must be perpendicular within $\pm 5^\circ$ of the pipe centerline.
Certifications	<p>Material Certificate – US Mill certs on all pressure retaining parts</p> <p>Pressure Test Certificate</p> <p>Certificate of Conformance</p> <p>NACE Certification (MR0175)</p>
Approvals	FM / FMC, ATEX, IECEX

**Model Number Information - Pro-T™ Insertion Mass Turbine Flowmeter**

\* See following page.

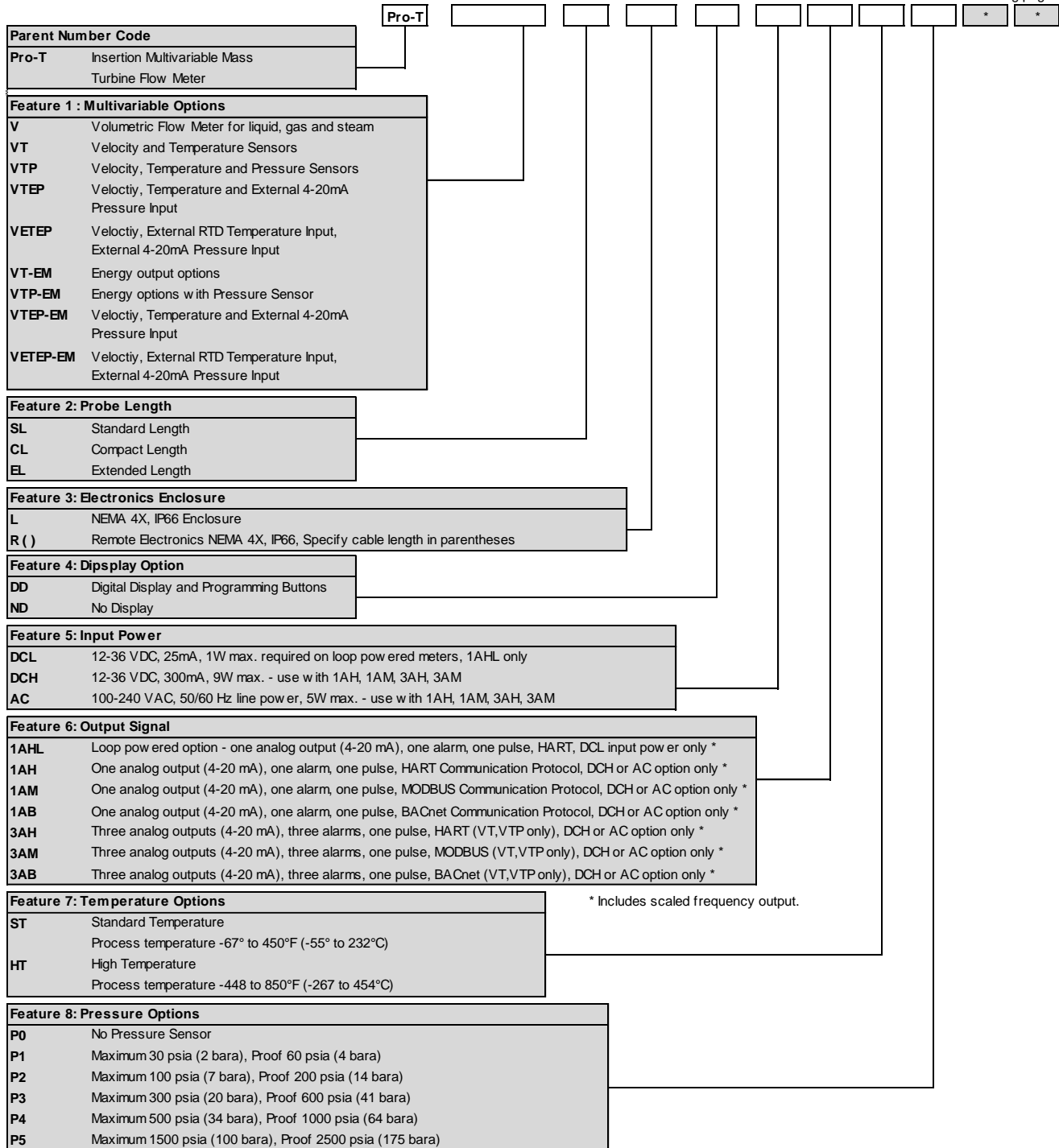

**Model Number Information - Pro-T™ Insertion Mass Turbine Flowmeter**

\* See previous page.

Pro-T   \*   \*   \*   \*   \*   \*   \*   \*   \*   \*   \*   \*

Feature 9: Process Connections			
CNPT	Compression, 2 inch NPT	P300	Packing Gland, 2 inch 300# Flange
C150	Compression, 2 inch 150# Flange	P40	Packing Gland, DN50 PN40 Flange
C16	Compression, DN50 PN16 Flange	PJ20	Packing Gland, JIS 20K Flange
CJ10	Compression, JIS 10K Flange	PNPTR	Packing Gland, 2 inch NPT, Retractor
C300	Compression, 2 inch 300# Flange	P150R	Packing Gland, 2 inch 150# Flange, Retractor
C40	Compression, DN50 PN40 Flange	P16R	Packing Gland, DN50 PN16 Flange, Retractor
CJ20	Compression, JIS 20K Flange	PJ10R	Packing Gland, JIS 10K Flange, Retractor
CJ30	Compression, JIS 30K Flange	P300R	Packing Gland, 2 inch 300# Flange, Retractor
C600	Compression, 2 inch 600# Flange	P40R	Packing Gland, DN50 PN40 Flange, Retractor
C63	Compression, DN50 PN63 Flange	PJ20R	Packing Gland, JIS 20K Flange, Retractor
C900	Compression, 2 inch 900# Flange	PJ30R	Packing Gland, JIS 30K Flange, Retractor
PNPT	Packing Gland, 2 inch NPT	P600R	Packing Gland, 2 inch 600# Flange, Retractor
P150	Packing Gland, 2 inch 150# Flange	P63R	Packing Gland, DN50 PN63 Flange, Retractor
P16	Packing Gland, DN50 PN16 Flange	P900R	Packing Gland, 2 inch 900# Flange, Retractor
PJ10	Packing Gland, JIS 10K Flange		

\* One removable retractor must be ordered if the process pressure is >50 psig.

Feature 10: Rotor Options	
R40	Gas or Steam, Vmin = 3.5 ft/sec, Vmax = 43 ft/sec, 40° pitch
R30	Gas or Steam, Vmin = 4.0 ft/sec, Vmax = 62.5 ft/sec, 30° pitch
R25	Gas or Steam, Vmin = 5.0 ft/sec, Vmax = 80 ft/sec, 25° pitch
R20	Gas or Steam, Vmin = 7.0 ft/sec, Vmax = 100 ft/sec, 20° pitch
R15	Gas or Steam, Vmin = 8.5 ft/sec, Vmax = 134.6 ft/sec, 15° pitch
R10	Gas or Steam, Vmin = 12.0 ft/sec, Vmax = 205 ft/sec, 10° pitch
L40	Liquid, Vmin = 1 ft/sec, Vmax = 30 ft/sec, 40° pitch

\* Velocities based on atmospheric conditions.

## Appendix B Approvals

### ATEX-IECEX Specifications / Approval

EN 60079-0 (2012+A11:2013)

IEC 60079-0 (2011)

Electrical Apparatus for explosive gas atmospheres  
General Requirements

EN IEC 60079-1 (2014)

Electrical Apparatus for explosive gas atmospheres  
Flameproof enclosures “d”

EN 60079-31 (2014)

Explosive atmospheres. Equipment dust ignition protection by enclosure "t"

Directive 2014/34/EU

Equipment Intended for use in Potentially Explosive Atmospheres (ATEX)

### Pro-T, ST, w/ATEX and IECEX Label



### Pro-T, HT, w/ATEX and IECEX Label

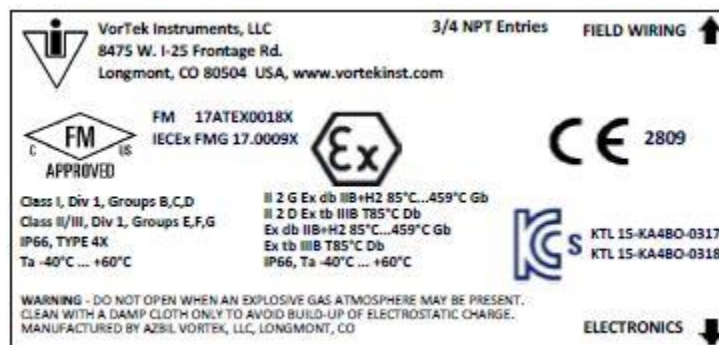



## Declaration of Conformity

VorTek Instruments, LLC  
8475 W I-25 Frontage Rd  
Longmont, CO 80504

Declares in sole responsibility that the product:

Vortex Flow Meter

Type M22 / M23 / M24 / M24R / Pro-T  
AX22 / AX23 / AX24 / AX24R

Conforms to the regulations of the European Directives:

EMC Directive 2014/30/EU

Low Voltage Directive 2014/35/EU

Pressure Equipment Directive 2014/68/EU

Explosion Protection Directive 2014/34/EU

Applied harmonized standards or normative documents:

EMC Directive 2014/30/EU

EN 61000-6-2: 2005 (immunity industrial environment)

EN 61000-6-3: 2007 +A1:2011 (emission residential, commercial)

EN 61326-1: 2013 (electrical equipment for measurement, control, and laboratory use)

EN 55011: 2009 +A1:2010 Group 1, Class A (ISM radio-frequency equipment)

Low Voltage Directive 2014/35/EU

EN IEC 61010-1: 2010 Safety requirements for electrical measuring, control and laboratory devices

Pressure Equipment Directive 2014/68/EU

Category I, Annex III, Module H Full Quality Assurance

Article 4, Paragraph 3 Sound Engineering Practice

AD 2000 Merkblätter Regulations for pressure vessel calculations

RoHS Directive 2011/65/EU

EN IEC 63000:2018 Technical assessment of electrical and electronic products with respect to RoHS

Explosion Protection Directive 2014/34/EU

EN IEC 60079-0: 2018 Electrical Apparatus for explosive gas atmospheres, General Requirements

EN IEC 60079-1: 2014-06 Electrical Apparatus for explosive gas atmospheres, flameproof enclosures "d"

EN IEC 60079-31: 2013 Explosive atmospheres. Equipment dust ignition protection by enclosure "t"

EC – Type Examination Certificate: FM 17ATEX0018X

Name and Address of the Notified Body

FM Approvals Europe Ltd  
Element 78  
1 Georges Quay Plaza  
Dublin D02 E440, Ireland

TÜV – Industrie Service GmbH  
TÜV SÜD Gruppe  
Dudenstraße 28  
D-68167 Mannheim



Eric Sanford

\_\_\_\_\_  
Managing Director



Steve Donjon

\_\_\_\_\_  
Quality Manager



Registrant: VorTek Instruments, LLC (Azbil VorTek, LLC)  
Equipment Name: Vortex Flowmeter  
Registration No's: MSIP-REM-A1V-A001  
MSIP-REM-A1V-A002  
MSIP-REM-A1V-A003  
Date of Registration: 2014-02-14

Technical assistance may be obtained by contacting Customer Service at:  
(888) 386-7835 or (303) 682-9999 in the USA





## Appendix C Flow Meter Calculations

### Flowing Velocity

$$V_f = \frac{f}{K_c}$$

### Volume Flow Rate

$$Q_v = V_f A$$

### Mass Flow Rate

$$Q_M = V_f A \rho$$

#### Where:

A = Cross sectional area of the pipe (ft<sup>2</sup>)

f = Turbine meter frequency (pulses / sec)

K<sub>c</sub> = Meter factor corrected for Reynolds Number (pulses / ft)

Q<sub>v</sub> = Volume flow rate (ft<sup>3</sup> / sec)

Q<sub>M</sub> = Mass flow rate (lbm / sec)

V<sub>f</sub> = Flowing velocity (ft / sec)

ρ = Density (lbm / ft<sup>3</sup>)

## Energy Flow Calculations

Energy is calculated for a steam supply/condensate return or hot/chilled water system. For steam/water, the meter must be located in the supply line; otherwise, the meter may be located in either the supply line or in the return line.

### Steam supply, water return, meter steam supply

$$\text{Energy} = \text{mdot} * (\text{h0} - \text{pctRet} * \text{h1})$$

**Where:**

mdot = mass flow at the meter, lbm/sec

pctRet = estimated percent of mass flow returned

h0 = Steam Enthalpy (t0, p)

h1 = Water Enthalpy (t1)

t0 = steam temperature

t1 = return water temperature

p = steam pressure

### Water supply and return, meter supply

$$\text{Energy} = \text{mdot} * (\text{h0} - \text{pctRet} * \text{h1})$$

**Where:**

h0 = Water Enthalpy (t0)

h1 = Water Enthalpy (t1)

t0 = supply water temperature

t1 = return water temperature

### Water supply and return, meter return

$$\text{Energy} = \text{mdot} * (\text{h1}/\text{pctRet} - \text{h0})$$

**Where:**

h0 = Water Enthalpy (t0)

h1 = Water Enthalpy (t1)

t0 = return water temperature

t1 = supply water temperature

The energy flow is positive if less energy is returned than is supplied. This implies that chilled water systems will indicate negative energy flow. Positive and negative energy flows are accumulated in separate totalizers.

## Fluid Calculations

### Calculations for Steam T & P

When “Steam T & P” is selected in the “Real Gas” selection of the Fluid Menu, the calculations are based on the equations below.

#### Density

The density of steam is calculated from the formula given by Keenan and Keys. The given equation is for the specific volume of the steam.

$$v = \frac{4.55504(T)}{p} + B$$

$$B = B_0 + B_0^2 g_1(\tau)\tau \cdot p + B_0^4 g_2(\tau)\tau^3 \cdot p^3 - B_0^{13} g_3(\tau)\tau^{12} \cdot p^{12}$$

$$B_0 = 1.89 - 2641.62 \cdot \tau \cdot 10^{80870\tau^2}$$

$$g_1(\tau) = 82.546 \cdot \tau - 1.6246 \cdot 10^5 \cdot \tau^2$$

$$g_2(\tau) = 0.21828 - 1.2697 \cdot 10^5 \cdot \tau^2$$

$$g_3(\tau) = 3.635 \cdot 10^{-4} - 6.768 \cdot 10^{64} \cdot \tau^{24}$$

Where tau is 1/ temperature in Kelvin.

The density can be found from  $1/v$  (specific volume of steam).

#### Viscosity

The viscosity is based on an equation given by Keenan and Keys.

$$\eta(\text{poise}) = \frac{1.501 \cdot 10^{-5} \sqrt{T}}{1 + 446.8/T}$$

Where T is the temperature in Kelvin

## Calculations for Gas (“Real Gas” and “Other Gas”)

Use this formula to determine the settings for “Real Gas; Gas” selections and “Other Gas” selections entered in the Fluid Menu. The calculations for gas were taken from Richard W. Miller, *Flow Measurement Engineering Handbook (Third Edition, 1996)*.

### Density

The density for real gases is calculated from the equation:

$$\rho = \frac{GM_{w,Air} P_f}{Z_f R_0 T_f}$$

Where G is the specific gravity,  $M_w$  is the molecular weight of air,  $p_f$  is the flowing pressure, Z is flowing compressibility,  $R_0$  is the universal gas constant, and T is the flowing temperature.

The specific gravity, and  $R_0$  are known and are stored in a table used by the Turbine meter.

The hard coefficient to find is the compressibility, Z. Z is found using the Redlich-Kwong Equation (Miller page 2-18).

The Redlich-Kwong Equation uses the reduced temperature and pressure to calculate the compressibility factor. The equations are non linear and an iterative solution is used. The Turbine program uses Newton’s Method on the Redlich-Kwong equations to iteratively find the compressibility factor. The critical temperature and pressure used in the Redlich-Kwong equation are stored in the fluid data table with the other coefficients.

### Viscosity

The viscosity for real gases is calculated using the exponential equation for two known viscosities. The equation is:

$$\mu_{cP} = aT_K^n$$

Where a and n are found from two known viscosities at two temperatures.

$$n = \frac{\ln[(\mu_{cP})_2 / (\mu_{cP})_1]}{\ln(T_{K2} / T_{K1})}$$

and

$$a = \frac{(\mu_{cP})_1}{T_{K1}^n}$$

## Calculations for Liquid

Use this formula to determine the settings for “Goyal-Dorais” selections and “Other Liquid” selections entered in the Fluid Menu. The liquid calculations were taken from Richard W. Miller, *Flow Measurement Engineering Handbook (Third Edition, 1996)*.

### Density

The liquid density is found using the Goyal-Doraiswamy Equation. Goyal-Doraiswamy uses the critical compressibility, critical pressure and critical temperature, along with the molecular weight to find the density. The equation for specific gravity is:

$$G_F = \frac{p_c Mw}{T_c} \left( \frac{0.008}{Z_c^{0.773}} - 0.01102 \frac{T_f}{T_c} \right)$$

The specific gravity can then be converted into density.

### Viscosity

The liquid viscosity is found by Andrade's equation. This uses two viscosities at different temperatures to extrapolate the viscosity.

Andrade's equation:

$$\mu = A_L \exp \frac{B_L}{T_{\text{deg R}}}$$

To find A and B

$$B_L = \frac{T_{\text{deg R}1} T_{\text{deg R}2} \ln(\mu_1 / \mu_2)}{T_{\text{deg R}2} - T_{\text{deg R}1}}$$

$$A_L = \frac{\mu_1}{\exp(B_L / T_{\text{deg R}1})}$$

The temperatures are all in degrees Rankin. Do not believe the subscript R means they are reduced temperatures.



## Appendix D Glossary

### A B C D

A	Cross sectional area.
ACFM	Actual Cubic Feet Per Minute (volumetric flow rate).
ASME	American Society of Mechanical Engineers.
BTU	British Thermal Unit, an energy measurement.
Cenelec	European Electrical Code.
Compressibility Factor	A factor used to correct for the non-ideal changes in a fluid's density due to changes in temperature and/or pressure.
CSA	Canadian Standards Association.
D	Diameter of a flow channel.

### E F G H

f	Frequency generated by a turbine flow meter, usually in Hz.
Flow Channel	A pipe, duct, stack, or channel containing flowing fluid.
Flow Profile	A map of the fluid velocity vector (usually non-uniform) in a cross-sectional plane of a flow channel (usually along a diameter).
FM	Factory Mutual.
Ft	Foot, 12 inches, a measure of length.
Ft <sup>2</sup>	Square feet, measure of area.
Ft <sup>3</sup>	Cubic feet, measure of volume.
GPM	Gallons Per Minute.
Hz	Hertz, cycles per second.

### I J K L

Insertion Flow Meter	A flow meter which is inserted into a hole in the user's pipeline.
Joule	A unit of energy equal to one watt for one second. Also equal to a Newton-meter.



LCD Liquid crystal display.

## M N O P

$\dot{m}$	Mass flow rate.
mA	Milli-amp, one thousandth of an ampere of current.
$\mu$	Viscosity, a measure of a fluid's resistance to shear stress. Honey has high viscosity, alcohol has low viscosity.
$\Delta P$	Permanent pressure loss.
P	Line pressure (psia or bar absolute).
$\rho_{act}$	The density of a fluid at the <u>actual</u> temperature and pressure operating conditions.
$\rho_{std}$	The density of a fluid at <u>standard</u> conditions (usually 14.7 psia and 20° C).
Permanent Pressure Loss	Unrecoverable drop in pressure.
Pitch	The angle of the blades of a turbine rotor.
PRTD	An resistance temperature detector (RTD) with platinum as its element. Used because of high stability.
psia	Pounds per square inch absolute (equals psig + atmospheric pressure). Atmospheric pressure is typically 14.696 psi at sea level.
psig	Pounds per square inch gauge.
$P_v$	Liquid vapor pressure at flowing conditions (psia or bar absolute).

## Q R S T

Q	Flow rate, usually volumetric.
Rangeability	Highest measurable flow rate divided by the lowest measurable flow rate.
Reynolds Number or Re	A dimensionless number equal to the density of a fluid times the velocity of the fluid times the diameter of the fluid channel, divided by the fluid viscosity (i.e., $Re = \rho V D / \mu$ ). The Reynolds number is an important number for turbine flow meters because it is used to determine the minimum measurable flow rate. It is the

---

	ratio of the inertial forces to the viscous forces in a flowing fluid.
Rotor	The velocity sensing element of a turbine flow meter. Rotors are manufactured with the blades at a certain pitch. The pitch of the rotor blades determine the maximum velocity the turbine flow meter can be used in.
RTD	Resistance temperature detector, a sensor whose resistance increases as the temperature rises.
scfm	Standard cubic feet per minute (flow rate converted to standard conditions, usually 14.696 psia and 68° F).
Totalizer	An electronic counter which records the total accumulated flow over a certain range of time.
Traverse	The act of moving a measuring point across the width of a flow channel.

## U V W X Y Z

Uncertainty	The closeness of agreement between the result of a measurement and the true value of the measurement.
V	Velocity or voltage.
VAC	Volts, alternating current.
VDC	Volts, direct current.

